



CHAPTER 1

Product Overview

Revised: February 3, 2012

This chapter describes the Catalyst 6500 series switches and contains these sections:

- [Catalyst 6503 Switch, page 1-2](#)
- [Catalyst 6503-E Switch, page 1-8](#)
- [Catalyst 6504-E Switch, page 1-13](#)
- [Catalyst 6506 Switch, page 1-18](#)
- [Catalyst 6506-E Switch, page 1-24](#)
- [Catalyst 6509 Switch, page 1-30](#)
- [Catalyst 6509-E Switch, page 1-36](#)
- [Catalyst 6509-NEB Switch, page 1-42](#)
- [Catalyst 6509-NEB-A Switch, page 1-49](#)
- [Catalyst 6509-V-E Switch, page 1-55](#)
- [Catalyst 6513 Switch, page 1-61](#)
- [Catalyst 6513-E Switch, page 1-67](#)



Note

The Catalyst 6000 series switches (Catalyst 6006 switch and Catalyst 6009 switch) are described in a separate publication, the *Catalyst 6000 Series Switches Installation Guide*.



Note

Throughout this publication, except where noted, the term *supervisor engine* is used to refer to Supervisor Engine 2, Supervisor Engine 32, Supervisor Engine 32 PISA, Supervisor Engine 720, and Supervisor Engine 720-10GE.

Catalyst 6503 Switch

The Catalyst 6503 switch is a 3-slot horizontal chassis supporting redundant power supplies, redundant supervisor engines, and slots for up to two modules. The chassis is NEBS L3 compliant. [Figure 1-1](#) shows the front view of the chassis and [Figure 1-2](#) shows the rear view of the chassis.

Figure 1-1 Catalyst 6503 Switch—Front View

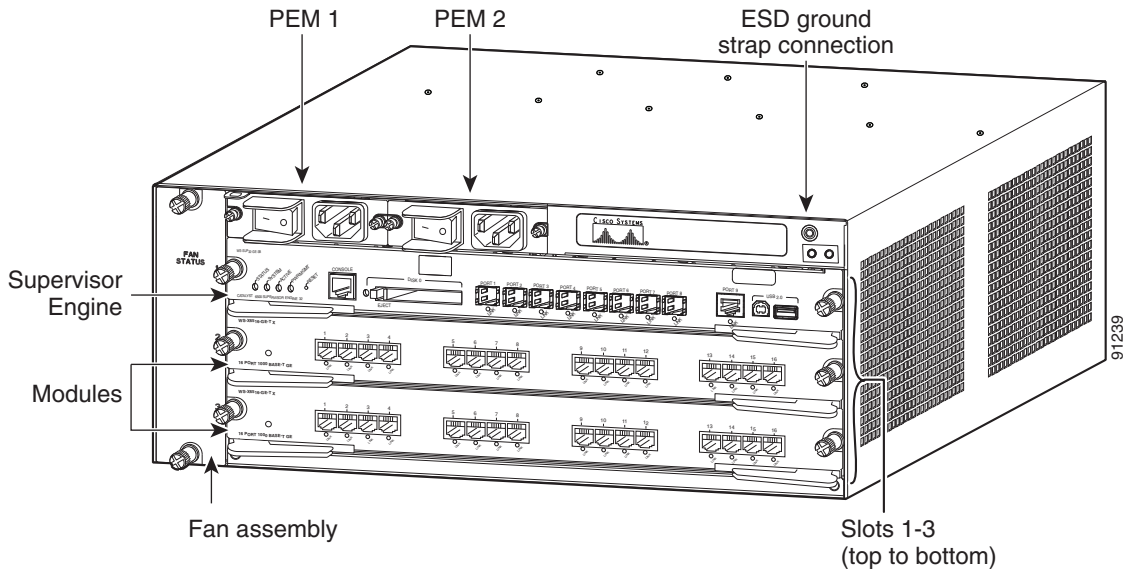

Figure 1-2 Catalyst 6503 Switch—Rear View

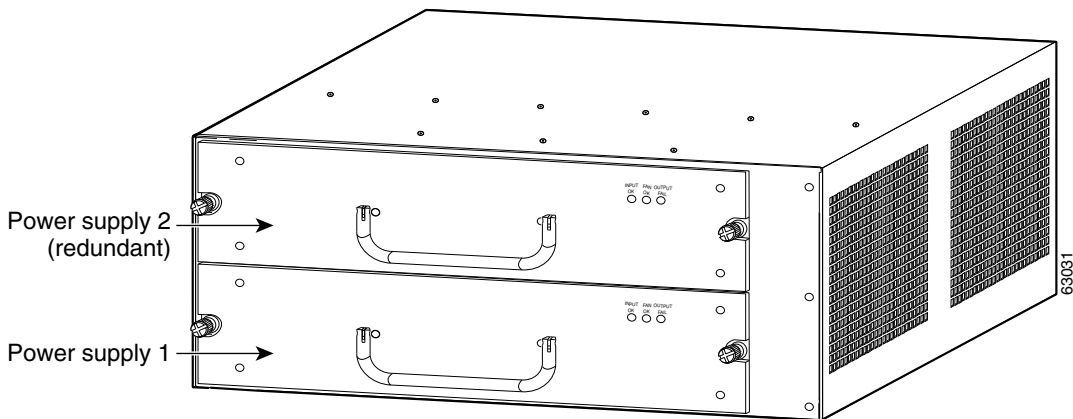

Table 1-1 lists the features of the Catalyst 6503 switch chassis.

Table 1-1 Catalyst 6503 Switch Features

Feature	Description
Chassis	<ul style="list-style-type: none"> • Three horizontal slots. Slots are numbered from 1 (top) to 3 (bottom).
Supervisor engine	<ul style="list-style-type: none"> • Supports Supervisor Engine 2, Supervisor Engine 32, Supervisor Engine 32 PISA, and Supervisor Engine 720. <p>Note Refer to your software release notes for the minimum software release versions required to support the supervisor engines.</p> <ul style="list-style-type: none"> • Supervisor engines can be installed in either slot 1 or slot 2. <p>Note Slots not occupied by supervisor engines can be used for modules. Check your software release notes for any restrictions on the type of module that can be installed.</p> <ul style="list-style-type: none"> • Supervisor Engine 720 with 10-GB uplink ports (VS-S720-10G-3C and VS-S720-10G-3CXL) is not supported on the Catalyst 6503 switch chassis. • Supervisor Engine 32, Supervisor Engine 32 PISA, or a Supervisor Engine 720 requires that the optional high-speed fan tray (FAN-MOD-3HS) be installed in the chassis. • Supervisor Engine 720 has built-in switching fabric. • The uplink ports are fully functional on the redundant supervisor engine in standby mode. <p>Note In systems with redundant supervisor engines, both supervisor engines must be the same model and have the same daughter card configurations. Each supervisor engine must have the resources to run the switch on its own, which means that all supervisor engine resources are duplicated. Identical supervisor engine memory configurations are recommended, but are not required as long as the supervisor engine with the smaller memory configuration is sufficient to run the configured features of the switch. Additionally, each supervisor engine must have its own flash device and console port connections.</p>
Modules	<ul style="list-style-type: none"> • Supports up to two Catalyst 6500 series modules. • Does not support the WS-C6500-SFM and WS-X6500-SFM2 Switch Fabric Modules. • Does not support the WS-X67xx modules. • Some Catalyst 6500 series modules may: <ul style="list-style-type: none"> – Not be supported – Require that you install a Supervisor Engine 720 – Have chassis slot restrictions – Require a specific software release level to operate <p>Note Check your software release notes for specific information.</p>

Table 1-1 Catalyst 6503 Switch Features (continued)

Feature	Description
Backplane bandwidth	<ul style="list-style-type: none"> • 32 GBps shared bus. • 720 GBps switch fabric.
Clock and VTT modules	<ul style="list-style-type: none"> • One replaceable clock module (CLK-7600=) provides clocking signals to the EOBC channel and the switching bus. • Nonreplaceable voltage termination (VTT) module provides reference voltage for bus signals.
Fan tray	<ul style="list-style-type: none"> • The chassis supports one hot-swappable fan tray. Two fan tray models are available: <ul style="list-style-type: none"> – FAN-MOD-3 (Standard fan tray—170 CFM). Supports Supervisor Engine 1 and Supervisor Engine 2 only; does not support Supervisor Engine 32 or Supervisor Engine 720. – FAN-MOD-3HS (Optional high-speed fan tray—270 CFM). Required for Supervisor Engine 32 and Supervisor Engine 720. Supports Supervisor Engine 2. <p>Note Both fan tray models contain four individual fans. The individual fans are not field replaceable; you must replace the fan tray in the event of a fan failure.</p> <p>Note The WS-C6503-E-FAN tray is not supported in the Catalyst 6503 chassis.</p> <ul style="list-style-type: none"> • Fan tray STATUS LED <ul style="list-style-type: none"> – Red—One or more individual fans have failed. – Green—Fan tray is operating normally.

Table 1-1 Catalyst 6503 Switch Features (continued)

Feature	Description
Power Entry Module (PEM) ¹	<ul style="list-style-type: none"> • A PEM is required for each installed power supply. <ul style="list-style-type: none"> – PEM-15A-AC (PEM for 950 W AC-input power supplies). – PEM-DC/3 (PEM for 950 W DC-input power supplies). – PEM-20A-AC+ (PEM for 1400 W AC-input power supplies).
Power supplies	<ul style="list-style-type: none"> • Supports one or two power supplies. The following power supplies are supported: <ul style="list-style-type: none"> – PWR-950-AC (950 W AC-input power supply). – PWR-950-DC (950 W DC-input power supply). – PWR-1400-AC (1400 W AC-input power supply). • Installed power supplies can be of different wattage ratings. Installed power supplies can be both AC-input, both DC-input, or one AC-input and one DC-input. Power supplies can be configured in either redundant or combined mode. <p>Note For Catalyst 6503 and Catalyst 6503-E chassis that are equipped with DC-input power supplies, the system (NEBS) ground serves as the primary safety ground and must be installed. The DC-input power supplies for these chassis do not have a separate ground.</p> <ul style="list-style-type: none"> • All Catalyst 6500 series AC-input power supplies require single-phase source AC. Source AC can be out of phase between multiple power supplies or multiple AC-power plugs on the same power supply because all AC power supply inputs are isolated. • Single power supplies are installed in the lower power supply bay. The second power supply is installed in the upper power supply bay. <p>Note For proper operation of the power supply OUTPUT FAIL LED, systems with single power supplies must be configured with a minimum of one fan tray and one supervisor engine. Systems with dual power supplies must have a minimum configuration of one fan tray, one supervisor engine, and one additional module. Failure to meet these minimum configuration requirements can cause a false power supply output fail signal.</p>

1. PEMs are required for Catalyst 6503 and Catalyst 6503-E switches only.

Table 1-2 lists the environmental and physical specifications of the Catalyst 6503 switch chassis.

Table 1-2 Catalyst 6503 Switch Specifications

Item	Specification
Environmental	
Temperature, operating	Certified for operation: 32° to 104°F (0° to 40°C) Designed and tested for operation: 32° to 131°F (0° to 55°C) Note The Catalyst 6500 series switches are equipped with internal air temperature sensors that are triggered at 40°C (104°F) generating a minor alarm and at 55°C (131°F) generating a major alarm.
Temperature, nonoperating and storage	Chassis unpackaged: -4° to 149°F (-20° to 65°C) Chassis in protective shipping package: -40° to 158°F (-40° to 70°C)
Thermal transition	0.5°C per minute (hot to cold) 0.33°C per minute (cold to hot)
Humidity (RH), ambient (noncondensing) operating	Operating: 5% to 90% Nonoperating and storage: 5% to 95%
Altitude, operating	Certified for operation: 0 to 6500 ft (0 to 2000 m) Designed and tested for operation: -200 to 10,000 ft (-60 to 3000 m)
Shock and vibration	This switch complies with Network Equipment Building Systems (NEBS) (Zone 4 per GR-63-Core) in the following areas: <ul style="list-style-type: none"> • Earthquake environment and criteria • Office vibration and criteria • Transportation vibration and criteria Shock <ul style="list-style-type: none"> • Operational—5 G 30 ms, half-sine (IEC 68-2-27) • Nonoperational—20 G, 7.5 ms, trapezoidal Vibration Operational—3 Hz to 500 Hz, Power Spectral Density (PSD)—0.0005 G ² /Hz at 10 Hz and 200 Hz. 5 dB/octave roll off at each end. 0.5 hours per axis (1.12 Grms).
Acoustic noise	64 to 76 dB. International Organization for Standardization (ISO) 7779: Bystander position operating to an ambient temperature of 86°F (30°C).

Table 1-2 Catalyst 6503 Switch Specifications (continued)

Item	Specification
Physical Characteristics Dimensions (H x W x D) Weight	<ul style="list-style-type: none"> • 7 x 17.37 x 21.75 in. (17.8 x 44.1 x 55.2 cm). • Chassis requires 4 RU¹. • The Catalyst 6503 switch chassis is designed to install in standard 19-inch equipment racks that meet ANSI/EIA 310-D, IEC 60297, and ETS 300-119 standards. • Chassis only: 27 lb (12.25 kg). • Chassis fully configured with 1 supervisor engine, 2 modules, 2 AC-input PEMs, and 2 AC-input power supplies: 85.4 lb (38.7 kg).
Airflow	<ul style="list-style-type: none"> • FAN-MOD-3 (Standard fan tray)—170 CFM • FAN-MOD-3HS (Optional high-speed fan tray)—270 CFM <p>Note To maintain proper air circulation through the Catalyst switch chassis, we recommend that you maintain a minimum 6-inch (15 cm) separation between a wall and the chassis air intake or a wall and the chassis air exhaust. You should also allow a minimum separation of 12 inches (30.5 cm) between the hot air exhaust on one chassis and the air intake on another chassis. Failure to maintain adequate air space can cause the chassis to overheat and the system to fail. On Catalyst chassis in which the airflow is from front to back, the chassis may be placed side-by-side.</p>

1. RU = rack units

Catalyst 6503-E Switch

The Catalyst 6503-E switch is an enhanced version of the Catalyst 6503 switch. The 3-slot horizontal chassis supports redundant power supplies, redundant supervisor engines, and slots for up to two modules. It also supports a greater power capacity per slot than the Catalyst 6503 switch chassis. The Catalyst 6503-E switch chassis is NEBS L3 compliant. [Figure 1-3](#) shows the front view of the chassis and [Figure 1-4](#) shows the rear view of the chassis.

Figure 1-3 Catalyst 6503-E Switch—Front View

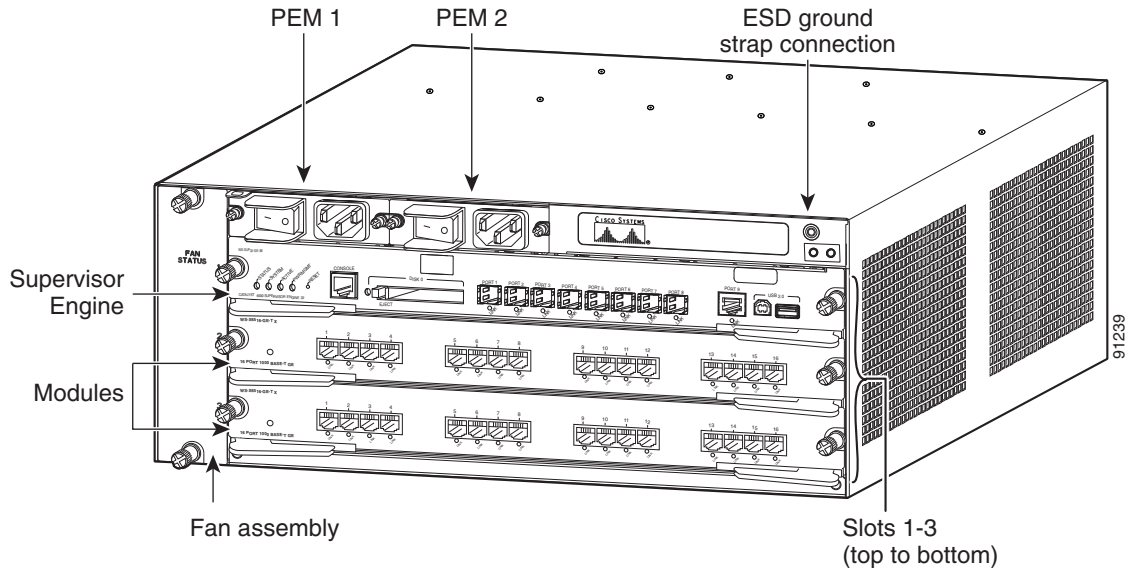

Figure 1-4 Catalyst 6503-E Switch—Rear View

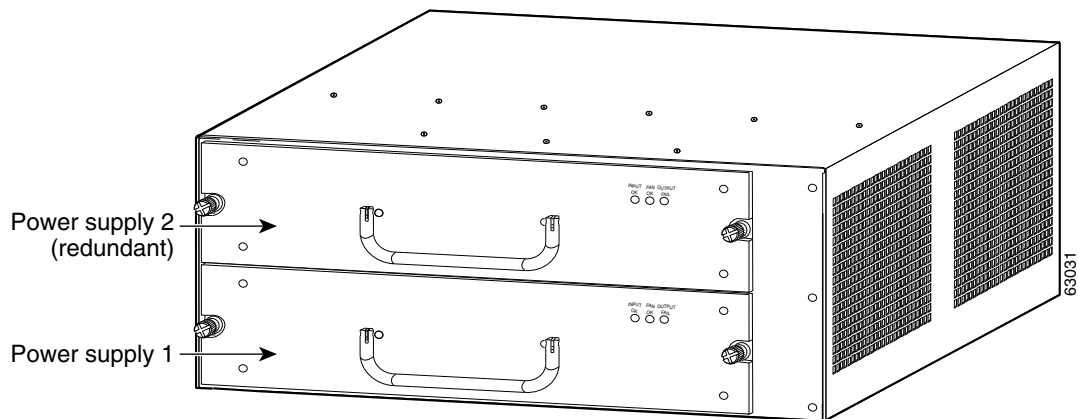

Table 1-3 lists the features of the Catalyst 6503-E switch chassis.

Table 1-3 Catalyst 6503-E Switch Features

Feature	Description
Chassis	<ul style="list-style-type: none"> • Three horizontal slots. Slots are numbered from 1 (top) to 3 (bottom).
Supervisor engine	<ul style="list-style-type: none"> • Supports Supervisor Engine 2, Supervisor Engine 32, Supervisor Engine 32 PISA, Supervisor Engine 720, Supervisor Engine 720-10GE, and Supervisor Engine 2T. <p>Note Refer to your software release notes for the minimum software release versions required to support the supervisor engines.</p> <ul style="list-style-type: none"> • Supervisor engines can be installed in either slot 1 or slot 2. <p>Note Slots not occupied by supervisor engines can be used for modules. Check your software release notes for any restrictions on the type of module that can be installed.</p> <ul style="list-style-type: none"> • Supervisor Engine 720, Supervisor Engine 720-10GE, and Supervisor Engine 2T have a built-in switching fabric. Switch Fabric Modules (WS-C6500-SFM and WS-X6500-SFM2) are not supported. • Supervisor Engine 32 and Supervisor Engine 32 PISA do not support the Switch Fabric Modules (WS-C6500-SFM and WS-X6500-SFM2). • The uplink ports are fully functional on the redundant supervisor engine when it is in standby mode. <p>Note In systems with redundant supervisor engines, both supervisor engines must be the same model and have the same daughter card configurations. Each supervisor engine must have the resources to run the switch on its own, which means that all supervisor engine resources are duplicated. Identical supervisor engine memory configurations are recommended, but are not required as long as the supervisor engine with the smaller memory configuration is sufficient to run the configured features of the switch. Additionally, each supervisor engine must have its own flash device and console port connections.</p>
Modules	<ul style="list-style-type: none"> • Supports up to two Catalyst 6500 series modules. • Does not support the WS-C6500-SFM and WS-X6500-SFM2 Switch Fabric Modules. • Some Catalyst 6500 series modules may: <ul style="list-style-type: none"> – Not be supported – Require that you install a certain supervisor engine – Have chassis slot restrictions – Require a specific software release level to operate <p>Note Check your software release notes for specific information on module support and restrictions.</p>

Table 1-3 Catalyst 6503-E Switch Features (continued)

Feature	Description
Backplane bandwidth	<ul style="list-style-type: none"> • 32 GBps shared bus. • 720 GBps switch fabric.
Clock and VTT module	<ul style="list-style-type: none"> • One replaceable clock module (CLK-7600=) provides clocking signals to the EOBC channel and the switching bus. • Nonreplaceable voltage termination (VTT) module provides reference voltage for bus signals.
Fan tray	<ul style="list-style-type: none"> • The chassis supports one hot-swappable fan tray. One fan tray model is available: <ul style="list-style-type: none"> – WS-C6503-E-FAN—282 CFM <p>Note The fan tray contains four individual fans. The individual fans are not field replaceable; you must replace the fan tray in the event of a fan failure.</p> <ul style="list-style-type: none"> • Fan tray STATUS LED <ul style="list-style-type: none"> – Red—One or more individual fans have failed. – Green—Fan tray is operating normally.
Power Entry Module (PEM) ¹	<ul style="list-style-type: none"> • A PEM is required for each installed power supply. <ul style="list-style-type: none"> – PEM-15A-AC (PEM for 950 W AC-input power supplies). – PEM-DC/3 (PEM for 950 W DC-input power supplies). – PEM-20A-AC+ (PEM for 1400 W AC-input power supplies).

Table 1-3 Catalyst 6503-E Switch Features (continued)

Feature	Description
Power supplies	<ul style="list-style-type: none"> • Supports one or two power supplies. The following power supplies are supported: <ul style="list-style-type: none"> – PWR-950-AC (950 W AC-input power supply). – PWR-950-DC (950 W DC-input power supply). – PWR-1400-AC (1400 W AC-input power supply). • Installed power supplies can be of different wattage ratings. Installed power supplies can be both AC-input, both DC-input, or one AC-input and one DC-input. Power supplies can be configured in either redundant or combined mode. • All Catalyst 6500 series AC-input power supplies require single-phase source AC. Source AC can be out of phase between multiple power supplies or multiple AC-power plugs on the same power supply because all AC power supply inputs are isolated. • Single power supplies are installed in the lower power supply bay. The second power supply is installed in the upper power supply bay. • Supervisor Engine 2T requires a 1400 W power supply to operate. <p>Note For proper operation of the power supply OUTPUT FAIL LED, systems with single power supplies must be configured with a minimum of one fan tray and one supervisor engine. Systems with dual power supplies must have a minimum configuration of one fan tray, one supervisor engine, and one additional module. Failure to meet these minimum configuration requirements can cause a false power supply output fail signal.</p>

1. PEMs are required for Catalyst 6503 and Catalyst 6503-E switches only.

Table 1-4 lists the environmental and physical specifications of the Catalyst 6503-E switch chassis.

Table 1-4 Catalyst 6503-E Switch Specifications

Item	Specification
Environmental	
Temperature, operating	<p>Certified for operation: 32° to 104°F (0° to 40°C)</p> <p>Designed and tested for operation: 32° to 131°F (0° to 55°C)</p> <p>Note The Catalyst 6500 series switches are equipped with internal air temperature sensors that are triggered at 104°F (40°C) generating a minor alarm and at 131°F (55°C) generating a major alarm.</p>
Temperature, nonoperating and storage	<p>Chassis unpackaged: –4° to 149°F (–20° to 65°C)</p> <p>Chassis in protective shipping package: –40° to 158°F (–40° to 70°C)</p>
Thermal transition	<p>0.5°C per minute (hot to cold)</p> <p>0.33°C per minute (cold to hot)</p>
Humidity (RH), ambient (noncondensing) operating	5% to 90%

Table 1-4 Catalyst 6503-E Switch Specifications (continued)

Item	Specification
Humidity (RH), ambient (noncondensing) nonoperating and storage Altitude, operating	5% to 95% Certified for operation: 0 to 6500 ft Designed and tested for operation: -200 to 10000 ft (-60 to 3000 m)
Shock and vibration	This switch complies with Network Equipment Building Systems (NEBS) (Zone 4 per GR-63-Core) in the following areas: <ul style="list-style-type: none"> • Earthquake environment and criteria • Office vibration and criteria • Transportation vibration and criteria <p>Shock</p> <ul style="list-style-type: none"> • Operational—5 G 30 ms, half-sine (IEC 68-2-27) • Nonoperational—20 G, 7.5 ms, trapezoidal <p>Vibration</p> <p>Operational—3 Hz to 500 Hz, Power Spectral Density (PSD)—0.0005 G²/Hz at 10 Hz and 200 Hz. 5 dB/octave roll off at each end. 0.5 hours per axis (1.12 Grms).</p>
Acoustic noise	64 to 76 dB. International Organization for Standardization (ISO) 7779: Bystander position operating to an ambient temperature of 86°F (30°C).
Physical characteristics	
Dimensions (H x W x D)	<ul style="list-style-type: none"> • 7 x 17.37 x 21.75 in. (17.8 x 44.1 x 55.2 cm). • Chassis requires 4 RU¹. • The Catalyst 6503-E switch chassis is designed to install in standard 19-inch equipment racks that meet ANSI/EIA 310-D, IEC 60297, and ETS 300-119 standards.
Weight	<ul style="list-style-type: none"> • Chassis only: 33 lb (15 kg). • Chassis fully configured with 1 supervisor engine, 2 modules, 2 AC-input PEMs, and 2 AC-input power supplies: 85.4 lb (38.7 kg).
Airflow	<ul style="list-style-type: none"> • WS-C6503-E-FAN—282 CFM <p>Note To maintain proper air circulation through the Catalyst switch chassis, we recommend that you maintain a minimum 6-inch (15 cm) separation between a wall and the chassis air intake or a wall and the chassis air exhaust. You should also allow a minimum separation of 12 inches (30.5 cm) between the hot air exhaust on one chassis and the air intake on another chassis. Failure to maintain adequate air space can cause the chassis to overheat and the system to fail. On Catalyst chassis in which the airflow is from front to back, the chassis may be placed side-by-side.</p>

1. RU = rack units

Catalyst 6504-E Switch

The Catalyst 6504-E switch is a 4-slot horizontal chassis that supports redundant power supplies, redundant supervisor engines, and slots for up to three modules. The Catalyst 6504-E switch chassis is NEBS L3 compliant. [Figure 1-5](#) shows the front view of the chassis and [Figure 1-6](#) shows the rear view of the chassis.

Figure 1-5 Catalyst 6504-E Switch—Front View

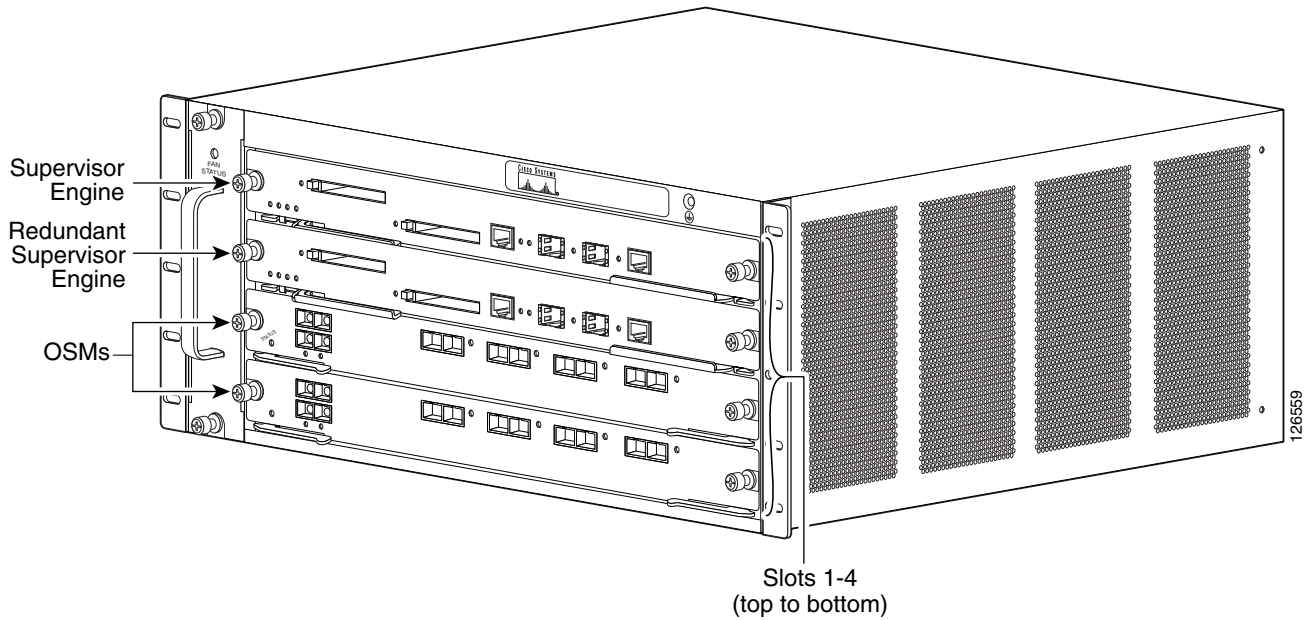

Figure 1-6 Catalyst 6504-E Switch—Rear View

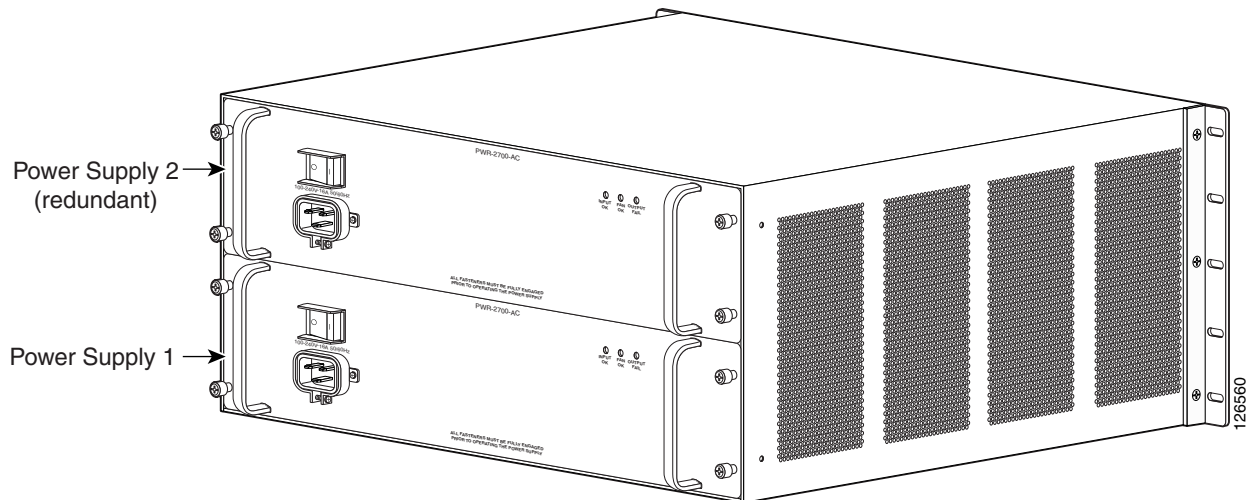

Table 1-5 lists the features of the Catalyst 6504-E switch chassis.

Table 1-5 Catalyst 6504-E Switch Features

Feature	Description
Chassis	<ul style="list-style-type: none"> Four horizontal slots. Slots are numbered from 1 (top) to 4 (bottom).
Supervisor engine	<ul style="list-style-type: none"> Supports Supervisor Engine 2, Supervisor Engine 32, Supervisor Engine 32 PISA, Supervisor Engine 720, and Supervisor Engine 720-10GE. <p>Note Refer to your software release notes for the minimum software release versions required to support the supervisor engines.</p> <ul style="list-style-type: none"> Supervisor engines are installed in slot 1 and slot 2. <p>Note Slots not occupied by supervisor engines can be used for modules. Check your software release notes for any restrictions on the type of module that can be installed.</p> <ul style="list-style-type: none"> Supervisor Engine 720, Supervisor Engine 720-10GE, and Supervisor Engine 2T have a built-in switching fabric. Switch Fabric Modules (WS-C6500-SFM and WS-X6500-SFM2) are not supported. Supervisor Engine 32 and Supervisor Engine 32 PISA do not support the Switch Fabric Modules (WS-C6500-SFM and WS-X6500-SFM2). The uplink ports are fully functional on the redundant supervisor engine when it is in standby mode. <p>Note In systems with redundant supervisor engines, both supervisor engines must be the same model and have the same daughter card configurations. Each supervisor engine must have the resources to run the switch on its own, which means that all supervisor engine resources are duplicated. Identical supervisor engine memory configurations are recommended, but are not required as long as the supervisor engine with the smaller memory configuration is sufficient to run the configured features of the switch. Additionally, each supervisor engine must have its own flash device and console port connections.</p>
Modules	<ul style="list-style-type: none"> Supports up to three Catalyst 6500 series modules. Does not support the WS-C6500-SFM and WS-X6500-SFM2 Switch Fabric Modules. Some Catalyst 6500 series modules may: <ul style="list-style-type: none"> Not be supported or have slot restrictions Require that you install a Supervisor Engine 720 Require a specific software release level to operate <p>Note Check your software release notes for specific information.</p>
Backplane bandwidth	<ul style="list-style-type: none"> 32 GBps shared bus. 720 GBps switch fabric.

Table 1-5 Catalyst 6504-E Switch Features (continued)

Feature	Description
Clock and VTT module	<ul style="list-style-type: none"> • One replaceable clock module (CLK-7600=) provides clocking signals to the EOBC channel and the switching bus. • Nonreplaceable voltage termination (VTT) module provides reference voltage for bus signals.
Fan tray	<ul style="list-style-type: none"> • The chassis supports one hot-swappable fan tray. One fan tray model is available: <ul style="list-style-type: none"> – FAN-MOD-4HS—300 CFM <p>Note The fan tray contains eight individual fans. The individual fans are not field replaceable; you must replace the fan tray in the event of a fan failure.</p> <ul style="list-style-type: none"> • Fan tray STATUS LED <ul style="list-style-type: none"> – Red—One or more individual fans have failed. – Green—Fan tray is operating normally.
Power supplies	<ul style="list-style-type: none"> • Supports one or two power supplies. The following power supplies are supported: <ul style="list-style-type: none"> – PWR-2700-AC/4 (2700 W AC-input power supply). – PWR-2700-DC/4 (2700 W DC-input power supply). • Installed power supplies can be both AC-input, both DC-input, or one AC-input and one DC-input. Power supplies can be configured in either redundant or combined mode. • All Catalyst 6500 series AC-input power supplies require single-phase source AC. Source AC can be out of phase between multiple power supplies or multiple AC-power plugs on the same power supply because all AC power supply inputs are isolated. • Single power supplies are installed in the lower power supply bay. The second power supply is installed in the upper power supply bay. <p>Note For proper operation of the power supply OUTPUT FAIL LED, systems with single power supplies must be configured with a minimum of one fan tray and one supervisor engine. Systems with dual power supplies must have a minimum configuration of one fan tray, one supervisor engine, and one additional module. Failure to meet these minimum configuration requirements can cause a false power supply output fail signal.</p>

Table 1-6 lists the environmental and physical specifications of the Catalyst 6504-E switch chassis.

Table 1-6 Catalyst 6504-E Switch Specifications

Item	Specification
Environmental Temperature, operating Temperature, nonoperating and storage Thermal transition	Certified for operation: 32° to 104°F (0° to 40°C) Designed and tested for operation: 32° to 131°F (0° to 55°C) Note The Catalyst 6500 series switches are equipped with internal air temperature sensors that are triggered at 104°F (40°C) generating a minor alarm and at 131°F (55°C) generating a major alarm. Chassis unpackaged: -4° to 149°F (-20° to 65°C) Chassis in protective shipping package: -40° to 158°F (-40° to 70°C) 0.5°C per minute (hot to cold) 0.33°C per minute (cold to hot)
Humidity (RH), ambient (noncondensing) operating Humidity (RH), ambient (noncondensing) nonoperating and storage Altitude, operating	5% to 90% 5% to 95% Certified for operation: 0 to 6500 ft (0 to 2000 m) Designed and tested for: -200 to 10,000 ft (-60 to 3000 m)
Shock and vibration	This switch complies with Network Equipment Building Systems (NEBS) (Zone 4 per GR-63-Core) in the following areas: <ul style="list-style-type: none"> • Earthquake environment and criteria • Office vibration and criteria • Transportation vibration and criteria Shock <ul style="list-style-type: none"> • Operational—5 G 30 ms, half-sine (IEC 68-2-27) • Nonoperational—20 G, 7.5 ms, trapezoidal Vibration Operational—3 Hz to 500 Hz. Power Spectral Density (PSD)—0.0005 G ² /Hz at 10 Hz and 200 Hz. 5 dB/octave roll off at each end. 0.5 hours per axis (1.12 Grms).

Table 1-6 Catalyst 6504-E Switch Specifications (continued)

Item	Specification
Acoustic noise	64 to 76 dB. International Organization for Standardization (ISO) 7779: Bystander position operating to an ambient temperature of 86°F (30°C).
Physical characteristics	<ul style="list-style-type: none"> • 8.75 x 17.5 x 21.75 in. (22.225 x 44.45 x 55.245 cm). • Chassis requires 5 RU¹. • The Catalyst 6504-E switch chassis is designed to install in standard 19-inch equipment racks that meet ANSI/EIA 310-D, IEC 60297, and ETS 300-119 standards.
Dimensions (H x W x D)	<ul style="list-style-type: none"> • 8.75 x 17.5 x 21.75 in. (22.225 x 44.45 x 55.245 cm).
Weight	<ul style="list-style-type: none"> • Chassis only: 27 lb (12.25 kg). • Chassis fully configured with 2 supervisor engines, 2 modules, and 2 AC-input power supplies: 97 lb (43.99 kg).
Airflow	<ul style="list-style-type: none"> • FAN-MOD-4HS—300 CFM <p>Note To maintain proper air circulation through the Catalyst switch chassis, we recommend that you maintain a minimum 6-inch (15 cm) separation between a wall and the chassis air intake or a wall and the chassis air exhaust. You should also allow a minimum separation of 12 inches (30.5 cm) between the hot air exhaust on one chassis and the air intake on another chassis. Failure to maintain adequate air space can cause the chassis to overheat and the system to fail. On Catalyst chassis in which the airflow is from front to back, the chassis may be placed side-by-side.</p>

1. RU = rack units

Catalyst 6506 Switch

The Catalyst 6506 switch is a 6-slot horizontal chassis supporting redundant power supplies, redundant supervisor engines, and slots for up to five modules. The chassis is NEBS L3 compliant. [Figure 1-7](#) shows a front view of the Catalyst 6506 switch chassis.

Figure 1-7 Catalyst 6506 Switch

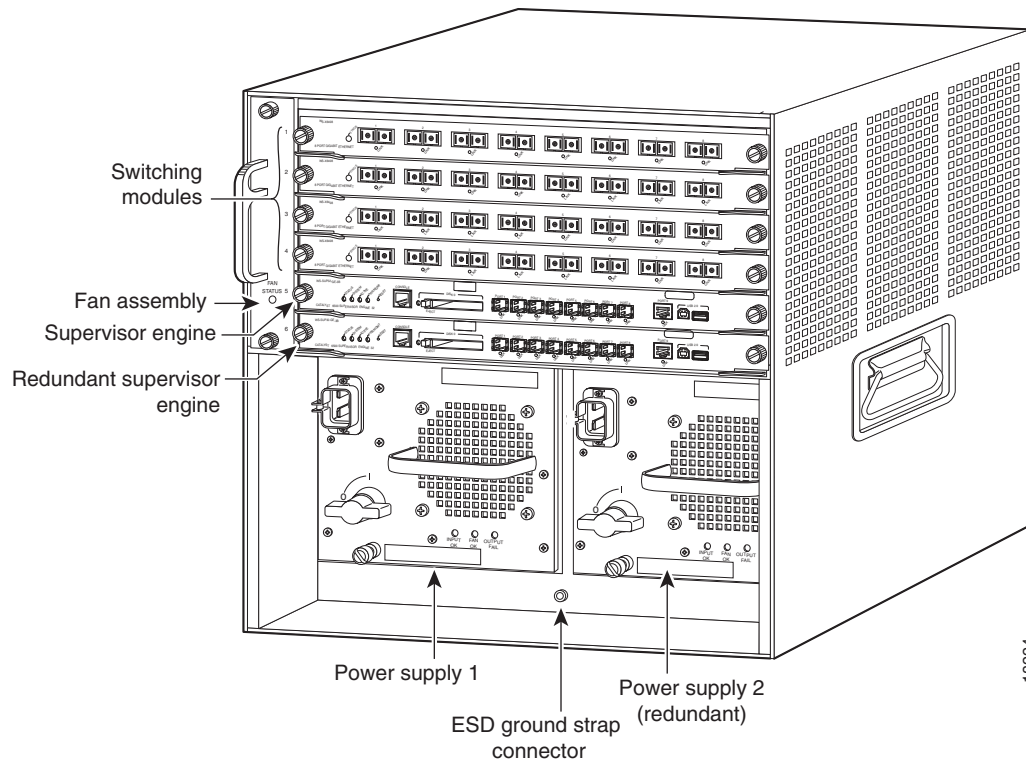

Table 1-7 lists the features of the Catalyst 6506 switch chassis.

Table 1-7 Catalyst 6506 Switch Features

Feature	Descriptions
Chassis	<ul style="list-style-type: none"> • Six horizontal slots. Slots are numbered from 1 (top) to 6 (bottom).
Supervisor engines	<ul style="list-style-type: none"> • Supports Supervisor Engine 2, Supervisor Engine 32, Supervisor Engine 32 PISA, Supervisor Engine 720, and Supervisor Engine 720-10GE. <p>Note Refer to your software release notes for the minimum software release versions required to support the supervisor engines.</p> <ul style="list-style-type: none"> – Supervisor Engine 2 must be installed in slot 1 or slot 2. – Supervisor Engine 32, Supervisor Engine 32 PISA, Supervisor Engine 720, and Supervisor Engine 720-10GE must be installed in slot 5 or slot 6. <p>Note Slots not occupied by supervisor engines can be used for modules. Check your software release notes for any restrictions on the type of module that can be installed.</p> <ul style="list-style-type: none"> • Supervisor Engine 32, Supervisor Engine 32 PISA, Supervisor Engine 720, and Supervisor Engine 720-10GE all require the high-speed fan tray (WS-C6K-6SLOT-FAN2) be installed in the chassis. You must also install a 2500 W or higher capacity power supply in the chassis to power the high-speed fan tray. <p>Note The 2500 W power supply, when supporting the high-speed fan tray, can be powered from either 120 VAC or 220 VAC.</p> <ul style="list-style-type: none"> • Supervisor Engine 720 and Supervisor Engine 720-10GE have a built-in switching fabric. Switch Fabric Modules (WS-C6500-SFM and WS-X6500-SFM2) are not supported by Supervisor Engine 720 and Supervisor Engine 720-10GE. • Supervisor Engine 32 and Supervisor Engine 32 PISA do not support the Switch Fabric Modules (WS-C6500-SFM and WS-X6500-SFM2). • The uplink ports are fully functional on the redundant supervisor engine in standby mode. <p>Note In systems with redundant supervisor engines, both supervisor engines must be the same model and have the same daughter card configurations. Each supervisor engine must have the resources to run the switch on its own, which means that all supervisor engine resources are duplicated. Identical supervisor engine memory configurations are recommended, but are not required as long as the supervisor engine with the smaller memory configuration is sufficient to run the configured features of the switch. Additionally, each supervisor engine must have its own flash device and console port connections.</p>

Table 1-7 Catalyst 6506 Switch Features (continued)

Feature	Descriptions
Modules	<ul style="list-style-type: none"> • Supports up to five Catalyst 6500 series modules. • WS-C6500-SFM and WS-X6500-SFM2 Switch Fabric Modules must be installed in slot 5 or slot 6. <p>Note Mixing WS-C6500-SFM and WS-X6500-SFM2 Switch Fabric Modules in the Catalyst 6506 chassis is allowed.</p> <ul style="list-style-type: none"> • Some Catalyst 6500 series modules may: <ul style="list-style-type: none"> – Not be supported – Require that you install a Supervisor Engine 720 – Have chassis slot restrictions – Require a specific software release level to operate <p>Note Check your software release notes for specific information on module support and restrictions.</p>
Backplane bandwidth	<ul style="list-style-type: none"> • 32 GBps shared bus. • 256 GBps switch fabric. • 720 GBps switch fabric.
Clock and VTT modules	<ul style="list-style-type: none"> • Two replaceable clock modules (WS-C6K-CL=) provide clocking signals to the EOBC channel and the switching bus. • Three replaceable voltage termination (VTT) modules (WS-C6K-VTT=) provide reference voltage for bus signals.
Fan tray	<ul style="list-style-type: none"> • The chassis supports one hot-swappable fan tray. Two fan tray models are available: <ul style="list-style-type: none"> – WS-C6K-6SLOT-FAN (Standard fan tray—227 CFM). Supports Supervisor Engine 1 and Supervisor Engine 2 only; does not support Supervisor Engine 32 or Supervisor Engine 720. – WS-C6K-6SLOT-FAN2 (Optional high-speed fan tray—420 CFM. Required for Supervisor Engine 32 and Supervisor Engine 720. Supports Supervisor Engine 1 and Supervisor Engine 2. <p>Note You must install a 2500 W or higher capacity power supply in the chassis to power the high-speed fan tray. The 2500 W power supply can be powered from either 120 VAC or 220 VAC.</p> <p>Note The fan trays contains six individual fans. The individual fans are not field replaceable; you must replace the fan tray in the event of a fan failure.</p> <ul style="list-style-type: none"> • Fan tray STATUS LED <ul style="list-style-type: none"> – Red—One or more individual fans have failed. – Green—Fan tray is operating normally.

Table 1-7 Catalyst 6506 Switch Features (continued)

Feature	Descriptions
Power supply	<ul style="list-style-type: none"> • Supports one or two power supplies. The following power supplies are supported: <ul style="list-style-type: none"> – WS-CAC-1000W (1000 W AC-input power supply). – WS-CAC-1300W (1300 W AC-input power supply). – WS-CDC-1300W (1300 W DC-input power supply). – WS-CAC-2500W (2500 W AC-input power supply). – WS-CDC-2500W (2500 W DC-input power supply). – WS-CAC-3000W (3000 W AC-input power supply). – WS-CAC-4000W-US (4000 W AC-input power supply). – WS-CAC-4000W-INT (4000 W AC-input power supply). – PWR-4000-DC (4000 W DC-input power supply). – WS-CAC-6000W (6000 W AC-input power supply). – PWR-6000-DC (6000 W DC-input power supply). – WS-CAC-8700W (8700 W AC-input power supply). <p>Note The 6000 W AC-input and DC-input power supplies, and the 8700 W AC-input power supply are limited to 4000 W maximum output when installed in the Catalyst 6506 chassis.</p> <ul style="list-style-type: none"> • Installed power supplies can be of different wattage ratings. Installed power supplies can also be both AC-input, both DC-input, or one AC-input and one DC-input. Power supplies can be configured in either redundant or combined mode. • All Catalyst 6500 series AC-input power supplies require single-phase source AC. Source AC can be out of phase between multiple power supplies or multiple AC-power plugs on the same power supply because all AC power supply inputs are isolated. • Single power supplies are installed in the left power supply bay. The second power supply is installed in the right power supply bay. • You must install a 2500 W or higher capacity power supply when using the Supervisor Engine 32 or the Supervisor Engine 720 and the high-speed fan tray. <p>Note For proper operation of the power supply OUTPUT FAIL LED, systems with single power supplies must be configured with a minimum of one fan tray and one supervisor engine. Systems with dual power supplies must have a minimum configuration of one fan tray, one supervisor engine, and one additional module. Failure to meet these minimum configuration requirements can cause a false power supply output fail signal.</p>

Table 1-8 lists the environmental and physical specifications of the Catalyst 6506 switch chassis.

Table 1-8 Catalyst 6506 Switch Specifications

Item	Specification
Environmental	
Temperature, operating	Certified for operation: 32° to 104°F (0° to 40°C) Designed and tested for operation: 32° to 130°F (0° to 55°C) Note The Catalyst 6500 series switches are equipped with internal air temperature sensors that are triggered at 104°F (40°C) generating a minor alarm and at 131°F (55°C) generating a major alarm.
Temperature, nonoperating and storage	Chassis unpackaged: -4° to 149°F (-20° to 65°C) Chassis in protective shipping package: -40° to 158°F (-40° to 70°C)
Thermal transition	0.5°C per minute (hot to cold) 0.33°C per minute (cold to hot)
Humidity (RH), ambient (noncondensing) operating	5% to 90%
Humidity (RH), ambient (noncondensing) nonoperating and storage	5% to 95%
Altitude, operating	Certified for operation: 0 to 6500 ft (0 to 2000 m) Designed and tested for operation: -200 to 10,000 ft (-60 to 3000 m)
Shock and vibration	This switch complies with Network Equipment Building Systems (NEBS) (Zone 4 per GR-63-Core) in the following areas: <ul style="list-style-type: none"> • Earthquake environment and criteria • Office vibration and criteria • Transportation vibration and criteria Shock <ul style="list-style-type: none"> • Operational—5 G 30 ms, half-sine (IEC 68-2-27) • Nonoperational—20 G, 7.5 ms, trapezoidal Vibration Operational—3 Hz to 500 Hz. Power Spectral Density (PSD)—0.0005 G ² /Hz at 10 Hz and 200 Hz. 5 dB/octave roll off at each end. 0.5 hours per axis (1.12 Grms).
Acoustic noise	53 to 61 dB. International Organization for Standardization (ISO) 7779: Bystander position operating to an ambient temperature of 86°F (30°C).

Table 1-8 Catalyst 6506 Switch Specifications (continued)

Item	Specification
Physical characteristics Dimensions (H x W x D) Weight	<ul style="list-style-type: none"> • 20.1 x 17.2 x 18.2 in. (51.1 x 43.7 x 46.0 cm). • Chassis depth including cable guide is 21.64 in. (55.0 cm). • Chassis requires 12 RU. • The Catalyst 6506 switch chassis is designed to install in standard 19-inch equipment racks that meet ANSI/EIA 310-D, IEC 60297, and ETS 300-119 standards. • Chassis only: 45 lb (20.4 kg). • Chassis fully configured with 1 supervisor engine, 5 switching modules, and 2 power supplies: 156.6 lb (71.0 kg).
Airflow	WS-C6K-6SLOT-FAN (Standard fan tray)—227 CFM. WS-C6K-6SLOT-FAN2 (Optional high-speed fan tray)—420 CFM. Note To maintain proper air circulation through the Catalyst switch chassis, we recommend that you maintain a minimum 6-inch (15 cm) separation between a wall and the chassis air intake or a wall and the chassis air exhaust. You should also allow a minimum separation of 12 inches (30.5 cm) between the hot air exhaust on one chassis and the air intake on another chassis. Failure to maintain adequate air space can cause the chassis to overheat and the system to fail. On Catalyst chassis in which the airflow is from front to back, the chassis may be placed side-by-side.

Catalyst 6506-E Switch

The Catalyst 6506-E switch is an enhanced version of the Catalyst 6506 switch. The 6-slot horizontal chassis supports redundant power supplies, redundant supervisor engines, and slots for up to five modules. It also supports a greater power capacity per slot than the Catalyst 6506 switch chassis. The Catalyst 6506-E switch chassis is NEBS L3 compliant. Figure 1-8 shows a front view of the Catalyst 6506-E switch.

Figure 1-8 Catalyst 6506-E Switch

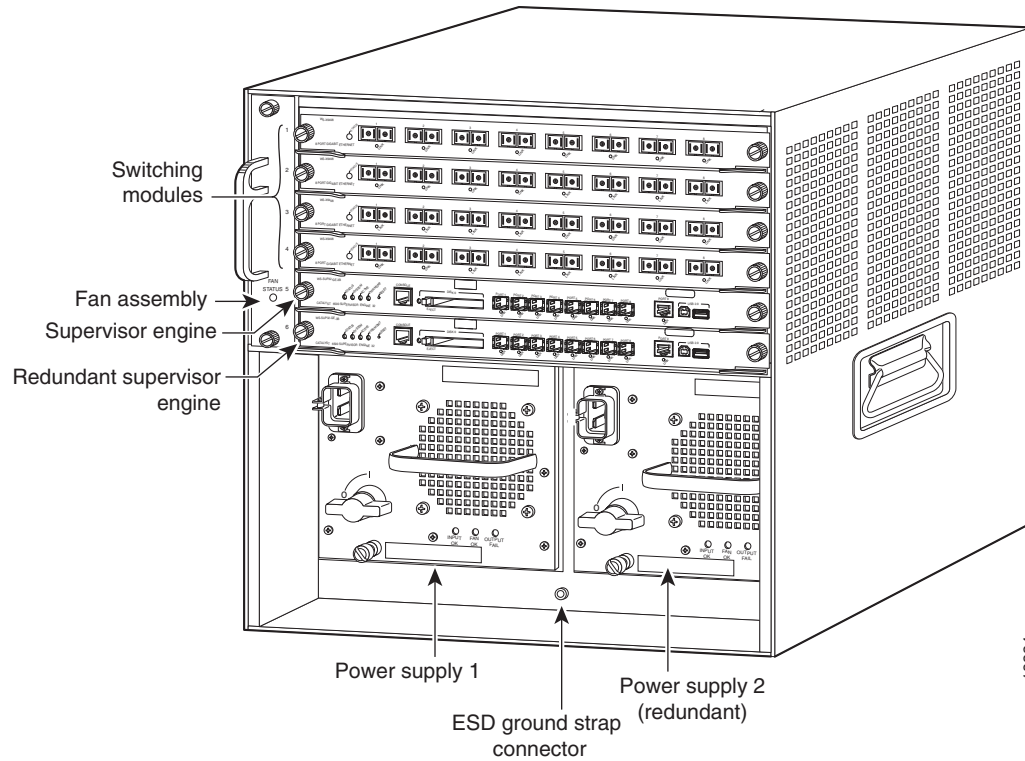

Table 1-9 lists the features of the Catalyst 6506-E switch chassis.

Table 1-9 Catalyst 6506-E Switch Features

Feature	Descriptions
Chassis	<ul style="list-style-type: none"> • Six horizontal slots. Slots are numbered from 1 (top) to 6 (bottom).
Supervisor engines	<ul style="list-style-type: none"> • Supports Supervisor Engine 2, Supervisor Engine 32, Supervisor Engine 32 PISA, Supervisor Engine 720, Supervisor Engine 720-10GE, and Supervisor Engine 2T. <p>Note Refer to your software release notes for the minimum software release versions required to support the supervisor engines.</p> <ul style="list-style-type: none"> – Supervisor Engine 2 must be installed in slot 1 and slot 2. – Supervisor Engine 32, Supervisor Engine 32 PISA, Supervisor Engine 720, Supervisor Engine 720-10GE, and Supervisor Engine 2T must be installed in slot 5 and slot 6. <p>Note Slots not occupied by supervisor engines can be used for modules. Check your software release notes for any restrictions on the type of module that can be installed.</p> <ul style="list-style-type: none"> • Supervisor Engine 720, Supervisor Engine 720-10GE, and Supervisor Engine 2T have a built-in switching fabric. Switch Fabric Modules (WS-C6500-SFM and WS-X6500-SFM2) are not supported. • Supervisor Engine 32 and Supervisor Engine 32 PISA do not support the Switch Fabric Modules (WS-C6500-SFM and WS-X6500-SFM2). • The uplink ports are fully functional on the redundant supervisor engine in standby mode. <p>Note In systems with redundant supervisor engines, both supervisor engines must be the same model and have the same daughter card configurations. Each supervisor engine must have the resources to run the switch on its own, which means that all supervisor engine resources are duplicated. Identical supervisor engine memory configurations are recommended, but are not required as long as the supervisor engine with the smaller memory configuration is sufficient to run the configured features of the switch. Additionally, each supervisor engine must have its own flash device and console port connections.</p>

Table 1-9 Catalyst 6506-E Switch Features (continued)

Feature	Descriptions
Modules	<ul style="list-style-type: none"> • Supports up to five Catalyst 6500 series modules. • WS-C6500-SFM and WS-X6500-SFM2 Switch Fabric Modules must be installed in slot 5 or slot 6. <p>Note Mixing WS-C6500-SFM and WS-X6500-SFM2 Switch Fabric Modules in the Catalyst 6506-E chassis is allowed.</p> <ul style="list-style-type: none"> • Some Catalyst 6500 series modules may: <ul style="list-style-type: none"> – Not be supported – Require that you install a Supervisor Engine 720 – Have chassis slot restrictions – Require a specific software release level to operate <p>Note Check your software release notes for specific information on module support and restrictions.</p>
Backplane bandwidth	<ul style="list-style-type: none"> • 32 GBps shared bus. • 256 GBps switch fabric. • 720 GBps switch fabric.
Clock and VTT modules	<ul style="list-style-type: none"> • Two replaceable clock modules (CLK-7600=) provide clocking signals to the EOBC channel and the switching bus. • Three replaceable voltage termination (VTT) modules (WS-C6K-VTT-E=) provide reference voltage for bus signals.
Fan tray	<ul style="list-style-type: none"> • The chassis supports one hot-swappable fan tray. One fan tray model is available: <ul style="list-style-type: none"> – WS-C6506-E-FAN—564 CFM <p>Note You must install a 2500 W or higher capacity power supply in the chassis to power the fan tray. The 2500 W power supply can be powered from either 120 VAC or 220 VAC.</p> <p>Note The fan tray contains six individual fans. The individual fans are not field replaceable; you must replace the fan tray in the event of a fan failure.</p> <ul style="list-style-type: none"> • Fan tray STATUS LED <ul style="list-style-type: none"> – Red—One or more individual fans have failed. – Green—Fan tray is operating normally.

Table 1-9 Catalyst 6506-E Switch Features (continued)

Feature	Descriptions
Power supply	<ul style="list-style-type: none"> • Supports one or two power supplies. The following power supplies are supported: <ul style="list-style-type: none"> – WS-CAC-2500W (2500 W AC-input power supply). – WS-CDC-2500W (2500 W DC-input power supply). – WS-CAC-3000W (3000 W AC-input power supply). – WS-CAC-4000W-US (4000 W AC-input power supply). – WS-CAC-4000W-INT (4000 W AC-input power supply). – PWR-4000-DC (4000 W DC-input power supply). – WS-CAC-6000W (6000 W AC-input power supply). – PWR-6000-DC (6000 W DC-input power supply). – WS-CAC-8700W-E (8700 W AC-input power supply). • Installed power supplies can be of different wattage ratings. Installed power supplies can also be both AC-input, both DC-input, or one AC-input and one DC-input. Power supplies can be configured in either redundant or combined mode. • All Catalyst 6500 series AC-input power supplies require single-phase source AC. Source AC can be out of phase between multiple power supplies or multiple AC-power plugs on the same power supply because all AC power supply inputs are isolated. • Single power supplies are installed in the left power supply bay. The second power supply is installed in the right power supply bay. • Supervisor Engine 2T requires a 3000 W or greater power supply to operate. <p>Note For proper operation of the power supply OUTPUT FAIL LED, systems with single power supplies must be configured with a minimum of one fan tray and one supervisor engine. Systems with dual power supplies must have a minimum configuration of one fan tray, one supervisor engine, and one additional module. Failure to meet these minimum configuration requirements can cause a false power supply output fail signal.</p>

Table 1-10 lists the environmental and physical specifications of the Catalyst 6506-E switch chassis.

Table 1-10 Catalyst 6506-E Switch Specifications

Item	Specification
Environmental Temperature, operating Temperature, nonoperating and storage Thermal transition Humidity (RH), ambient (noncondensing) operating Humidity (RH), ambient (noncondensing) nonoperating and storage Altitude, operating	Certified for operation: 32° to 104°F (0° to 40°C) Designed and tested for operation: 32° to 131°F (0° to 55°C) Note The Catalyst 6500 series switches are equipped with internal air temperature sensors that are triggered at 104°F (40°C) generating a minor alarm and at 131°F (55°C) generating a major alarm. Chassis unpackaged: -4° to 149°F (-20° to 65°C) Chassis in protective shipping package: -40° to 158°F (-40° to 70°C) 0.5°C per minute (hot to cold) 0.33°C per minute (cold to hot) 5% to 90% 5% to 95% Certified for operation: 0 to 6500 ft (0 to 2000 m) Designed and tested for operation: -200 to 10,000 ft (-60 to 3000 m)
Shock and vibration	This switch complies with Network Equipment Building Systems (NEBS) (Zone 4 per GR-63-Core) in the following areas: <ul style="list-style-type: none"> • Earthquake environment and criteria • Office vibration and criteria • Transportation vibration and criteria Shock <ul style="list-style-type: none"> • Operational—5 G 30 ms, half-sine (IEC 68-2-27) • Nonoperational—20 G, 7.5 ms, trapezoidal Vibration Operational—3 Hz to 500 Hz. Power Spectral Density (PSD)—0.0005 G ² /Hz at 10 Hz and 200 Hz. 5 dB/octave roll off at each end. 0.5 hours per axis (1.12 Grms).
Acoustic noise	53 to 61 dB. International Organization for Standardization (ISO) 7779: Bystander position operating to an ambient temperature of 86°F (30°C).

Table 1-10 Catalyst 6506-E Switch Specifications (continued)

Item	Specification
Physical characteristics Dimensions (H x W x D) Weight	<ul style="list-style-type: none"> • 19.2 x 17.5 x 18.2 in. (48.8 x 44.5 x 46.0 cm). • Chassis depth including cable guide is 21.64 in. (55.0 cm). • Chassis requires 12 RU. • The Catalyst 6506-E switch chassis is designed to install in standard 19-inch equipment racks that meet ANSI/EIA 310-D, IEC 60297, and ETS 300-119 standards. Chassis only: 50 lb (22.7 kg). Chassis fully configured with 1 supervisor engine, 5 switching modules, and 2 power supplies: 159 lb (72.3 kg).
Airflow	WS-C6506-E-FAN—564 CFM. Note We recommend that you maintain a minimum air space of 6 inches (16 cm) between walls and the chassis air vents and a minimum horizontal separation of 12 inches (30.5 cm) between two chassis to prevent overheating.

Catalyst 6509 Switch

The Catalyst 6509 switch is a 9-slot horizontal chassis supporting redundant power supplies, redundant supervisor engines, and slots for up to eight modules. The chassis is NEBS L3 compliant. [Figure 1-9](#) shows a front view of the Catalyst 6509 switch chassis.

Figure 1-9 Catalyst 6509 Switch

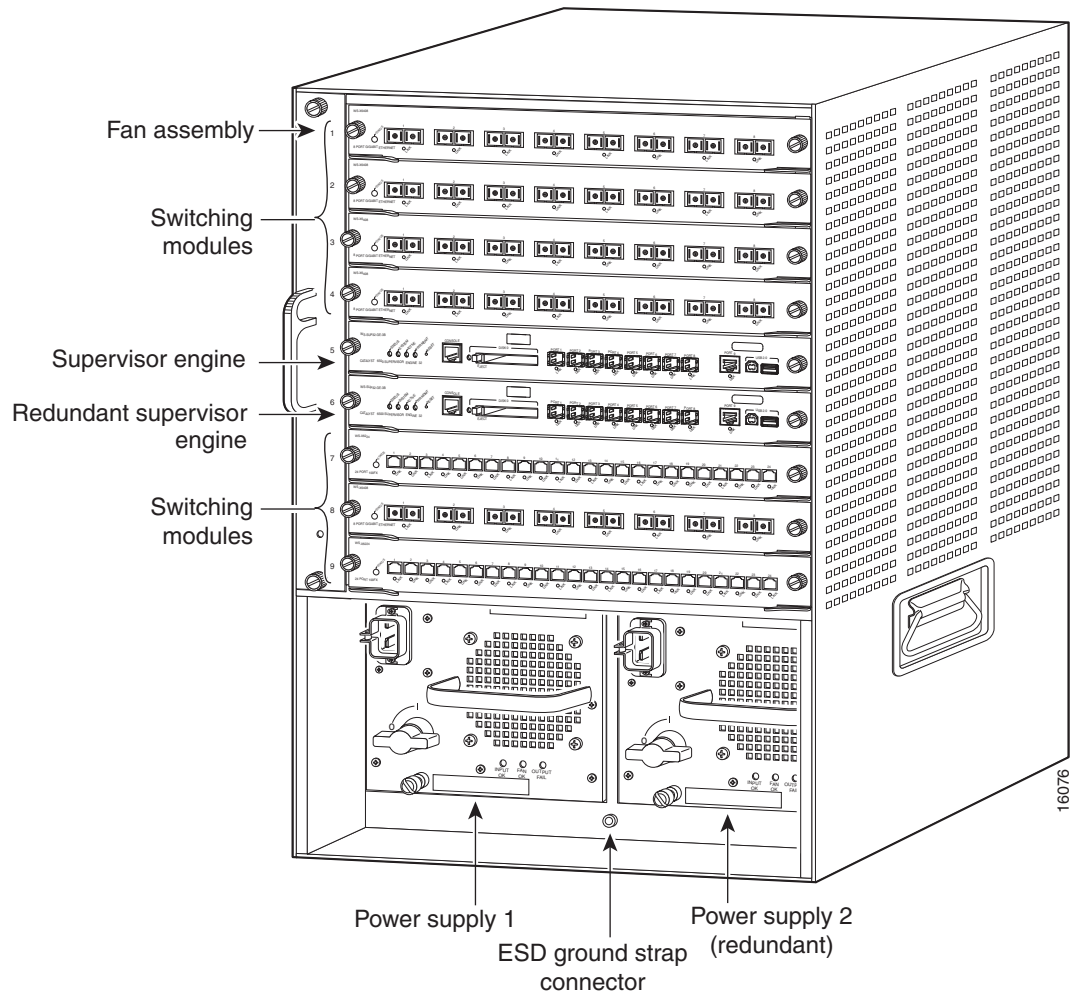

Table 1-11 lists the features of the Catalyst 6509 switch chassis.

Table 1-11 Catalyst 6509 Switch Features

Feature	Description
Chassis	<ul style="list-style-type: none"> • Nine horizontal slots. Slots are numbered from 1 (top) to 9 (bottom).
Supervisor engines	<ul style="list-style-type: none"> • Supports Supervisor Engine 2, Supervisor Engine 32, Supervisor Engine 32 PISA, Supervisor Engine 720, and Supervisor Engine 720-10GE. <p>Note Refer to your software release notes for the minimum software release versions required to support the supervisor engines.</p> <ul style="list-style-type: none"> – Supervisor Engine 2 must be installed in slot 1 and slot 2. – Supervisor Engine 32, Supervisor Engine 32 PISA, Supervisor Engine 720, and Supervisor Engine 720-10GE must be installed in slot 5 and slot 6. <p>Note Slots not occupied by supervisor engines can be used for modules. Check your software release notes for any restrictions on the type of module that can be installed.</p> <ul style="list-style-type: none"> • Supervisor Engine 32, Supervisor Engine 32 PISA, Supervisor Engine 720, and Supervisor Engine 720-10GE require that the high-speed fan tray be installed in the chassis. You must also install a 2500 W or higher capacity power supply in the chassis to power the high-speed fan tray. <p>Note The 2500 W power supply, when supporting the high-speed fan tray, can be powered from either 120 VAC or 220 VAC.</p> <ul style="list-style-type: none"> • Supervisor Engine 720 and Supervisor Engine 720-10GE have a built-in switching fabric. Switch Fabric Modules (WS-C6500-SFM and WS-X6500-SFM2) are not supported by Supervisor Engine 720 and Supervisor Engine 720-10GE. • Supervisor Engine 32 and Supervisor Engine 32 PISA do not support the Switch Fabric Modules (WS-C6500-SFM and WS-X6500-SFM2). • The uplink ports are fully functional on all redundant supervisor engine models when they are in standby mode. <p>Note In systems with redundant supervisor engines, both supervisor engines must be the same model and have the same daughter card configurations. Each supervisor engine must have the resources to run the switch on its own, which means that all supervisor engine resources are duplicated. Identical supervisor engine memory configurations are recommended, but are not required as long as the supervisor engine with the smaller memory configuration is sufficient to run the configured features of the switch. Additionally, each supervisor engine must have its own flash device and console port connections.</p>

Table 1-11 Catalyst 6509 Switch Features (continued)

Feature	Description
Modules	<ul style="list-style-type: none"> • Supports up to eight Catalyst 6500 series modules. • WS-C6500-SFM and WS-X6500-SFM2 Switch Fabric Modules must be installed in slot 5 or slot 6. <p>Note Mixing WS-C6500-SFM and WS-X6500-SFM2 Switch Fabric Modules in the Catalyst 6509 chassis is allowed.</p> <ul style="list-style-type: none"> • Some Catalyst 6500 series modules may: <ul style="list-style-type: none"> – Not be supported – Require that you install a Supervisor Engine 720 – Have chassis slot restrictions – Require a specific software release level to operate <p>Note Check your software release notes for specific information on modules supported and restrictions.</p>
Backplane bandwidth	<ul style="list-style-type: none"> • 32 GBps shared bus. • 256 GBps switch fabric. • 720 GBps switch fabric.
Clock and VTT modules	<ul style="list-style-type: none"> • Two replaceable clock modules (WS-C6K-CL=) provide clocking signals to the EOBC channel and the switching bus. • Three replaceable voltage termination (VTT) modules (WS-C6K-VTT=) provide reference voltage for bus signals.
Fan tray	<ul style="list-style-type: none"> • The chassis supports one hot-swappable fan tray. Two fan tray models are available: <ul style="list-style-type: none"> – WS-C6K-9SLOT-FAN (Standard fan tray—340 CFM). Supports Supervisor Engine 1 and Supervisor Engine 2 only; does not support Supervisor Engine 32 or Supervisor Engine 720. – WS-C6K-9SLOT-FAN2 (Optional high-speed fan tray—630 CFM). Required for Supervisor Engine 32 and Supervisor Engine 720. Supports Supervisor Engine 1 and Supervisor Engine 2. <p>Note You must install a 2500 W or higher capacity power supply in the chassis to power the high-speed fan tray. The 2500 W power supply can be powered from either 120 VAC or 220 VAC.</p> <p>Note The fan tray contains nine individual fans. The individual fans are not field replaceable; you must replace the fan tray in the event of a fan failure.</p> <ul style="list-style-type: none"> • Fan tray STATUS LED <ul style="list-style-type: none"> – Red—One or more individual fans have failed. – Green—Fan tray is operating normally.

Table 1-11 Catalyst 6509 Switch Features (continued)

Feature	Description
Power supply	<ul style="list-style-type: none"> • Supports one or two power supplies. The following power supply models are supported: <ul style="list-style-type: none"> – WS-CAC-1000W (1000 W AC-input power supply). – WS-CAC-1300W (1300 W AC-input power supply). – WS-CDC-1300W (1300 W DC-input power supply). – WS-CAC-2500W (2500 W AC-input power supply). – WS-CDC-2500W (2500 W DC-input power supply). – WS-CAC-3000W (3000 W AC-input power supply). – WS-CAC-4000W-US (4000 W AC-input power supply). – WS-CAC-4000W-INT (4000 W AC-input power supply). – PWR-4000-DC (4000 W DC-input power supply). – WS-CAC-6000W (6000 W AC-input power supply). – PWR-6000-DC (6000 W DC-input power supply). – WS-CAC-8700W-E (8700 W AC-input power supply). <p>Note The 6000 W AC-input and DC-input power supplies and the 8700 W AC-input power supply are limited to 4000 W maximum output when installed in the Catalyst 6509 chassis.</p> <ul style="list-style-type: none"> • Installed power supplies can be of different wattage ratings. Installed power supplies can also be both AC-input, both DC-input, or one AC-input and one DC-input. Power supplies can be configured in either redundant or combined mode. • All Catalyst 6500 series AC-input power supplies require single-phase source AC. Source AC can be out of phase between multiple power supplies or multiple AC-power plugs on the same power supply because all AC power supply inputs are isolated. • Single power supplies are installed in the left power supply bay. The second (redundant) power supply is installed in the right power supply bay. • You must install a 2500 W or higher capacity power supply when using the Supervisor Engine 32 or the Supervisor Engine 720 and the high-speed fan tray. <p>Note For proper operation of the power supply OUTPUT FAIL LED, systems with single power supplies must be configured with a minimum of one fan tray and one supervisor engine. Systems with dual power supplies must have a minimum configuration of one fan tray, one supervisor engine, and one additional module. Failure to meet these minimum configuration requirements can cause a false power supply output fail signal.</p>

Table 1-12 lists the environmental and physical specifications of the Catalyst 6509 switch chassis.

Table 1-12 Catalyst 6509 Switch Specifications

Item	Specification
Environmental	
Temperature, operating	Certified for operation: 32° to 104°F (0° to 40°C) Designed and tested for operation: 32° to 131°F (0° to 55°C) Note The Catalyst 6500 series switches are equipped with internal air temperature sensors that are triggered at 104°F (40°C) generating a minor alarm and at 131°F (55°C) generating a major alarm.
Temperature, nonoperating and storage	Chassis unpackaged: -4° to 149°F (-20° to 65°C) Chassis in protective shipping package: -40° to 158°F (-40° to 70°C)
Thermal transition	0.5°C per minute (hot to cold) 0.33°C per minute (cold to hot)
Humidity (RH), ambient (noncondensing) operating	5% to 90%
Humidity (RH), ambient (noncondensing) nonoperating and storage	5% to 95%
Altitude, operating	Certified for operation: 0 to 6500 ft (0 to 2000 m) Designed and tested for operation: -200 to 10,000 ft (-60 to 3000 m)
Shock and vibration	This switch complies with Network Equipment Building Systems (NEBS) (Zone 4 per GR-63-Core) in the following areas: <ul style="list-style-type: none"> • Earthquake environment and criteria • Office vibration and criteria • Transportation vibration and criteria Shock <ul style="list-style-type: none"> • Operational—5 G 30 ms, half-sine (IEC 68-2-27) • Nonoperational—20 G, 7.5 ms, trapezoidal Vibration Operational—3 Hz to 500 Hz. Power Spectral Density (PSD)—0.0005 G ² /Hz at 10 Hz and 200 Hz. 5 dB/octave roll off at each end. 0.5 hours per axis (1.12 Grms).
Acoustic noise	53.6 to 68 dB. International Organization for Standardization (ISO) 7779: Bystander position operating to an ambient temperature of 86°F (30°C).

Table 1-12 Catalyst 6509 Switch Specifications (continued)

Item	Specification
Physical characteristics Dimensions (H x W x D) Weight	<ul style="list-style-type: none"> • 25.3 x 17.2 x 18.2 in. (64.0 x 43.7 x 46.0 cm). • Chassis depth including cable guide is 21.64 in. (55.0 cm). • Chassis requires 15 RU¹. • The Catalyst 6509 switch chassis is designed to install in standard 19-inch equipment racks that meet ANSI/EIA 310-D, IEC 60297, and ETS 300-119 standards. Chassis only: 55 lb (24.9 kg). Chassis fully configured with 1 supervisor engine, 8 switching modules, and 2 power supplies: 194.5 lb (88.2 kg).
Airflow	WS-C6K-9SLOT-FAN (Standard fan tray)—340 CFM WS-C6K-9SLOT-FAN2 (Optional high-speed fan tray)—630 CFM Note To maintain proper air circulation through the Catalyst switch chassis, we recommend that you maintain a minimum 6-inch (15 cm) separation between a wall and the chassis air intake or a wall and the chassis air exhaust. You should also allow a minimum separation of 12 inches (30.5 cm) between the hot air exhaust on one chassis and the air intake on another chassis. Failure to maintain adequate air space can cause the chassis to overheat and the system to fail. On Catalyst chassis in which the airflow is from front to back, the chassis may be placed side-by-side.

1. RU = rack units

Catalyst 6509-E Switch

The Catalyst 6509-E switch is an enhanced version of the Catalyst 6509 switch. The 9-slot horizontal chassis supports redundant power supplies, redundant supervisor engines, and slots for up to eight modules. It also supports a greater power capacity per slot than the Catalyst 6509 switch chassis. The Catalyst 6509-E switch chassis is NEBS L3 compliant. Figure 1-10 shows the Catalyst 6509-E switch.

Figure 1-10 Catalyst 6509-E Switch

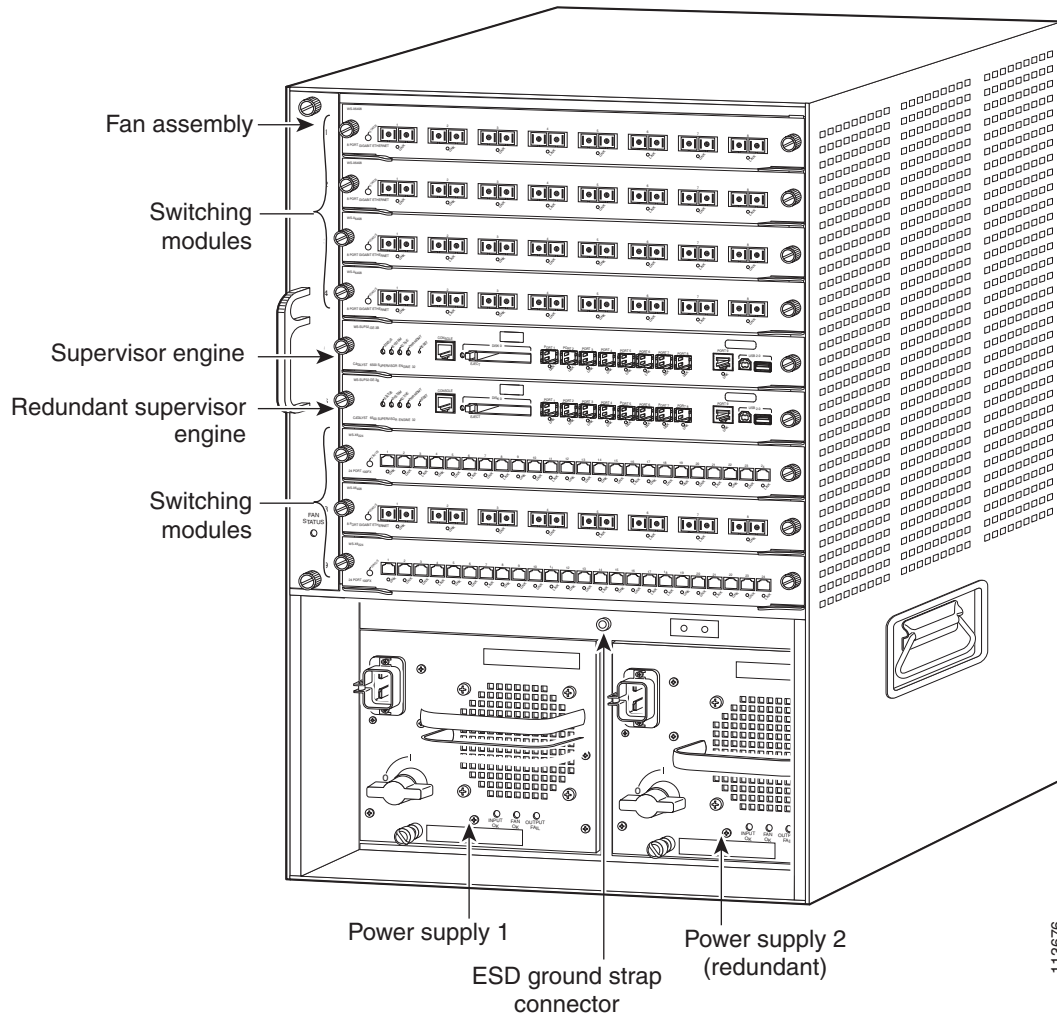

113676

Table 1-13 lists the features of the Catalyst 6509-E switch chassis.

Table 1-13 Catalyst 6509-E Switch Features

Feature	Description
Chassis	<ul style="list-style-type: none"> • Nine horizontal slots. Slots are numbered from (1) top to (9) bottom.
Supervisor engines	<ul style="list-style-type: none"> • Supports Supervisor Engine 2, Supervisor Engine 32, Supervisor Engine 32 PISA, Supervisor Engine 720, Supervisor Engine 720-10GE, and Supervisor Engine 2T. <p>Note Refer to your software release notes for the minimum software release versions required to support the supervisor engines.</p> <ul style="list-style-type: none"> – Supervisor Engine 2 must be installed in slot 1 and slot 2. – Supervisor Engine 32, Supervisor Engine 32 PISA, Supervisor Engine 720, Supervisor Engine 720-10GE, and Supervisor Engine 2T must be installed in slot 5 and slot 6. <p>Note Slots not occupied by supervisor engines can be used for modules. Check your software release notes for any restrictions on the type of module that can be installed.</p> <ul style="list-style-type: none"> • Supervisor Engine 720 and Supervisor Engine 720-10GE , and Supervisor Engine 2T have a built-in switching fabric. Switch Fabric Modules (WS-C6500-SFM and WS-X6500-SFM2) are not supported. • Supervisor Engine 32 and Supervisor Engine 32 PISA do not support the Switch Fabric Modules (WS-C6500-SFM and WS-X6500-SFM2). • The uplink ports are fully functional on all redundant supervisor engine models when they are in standby mode. <p>Note In systems with redundant supervisor engines, both supervisor engines must be the same model and have the same daughter card configurations. Each supervisor engine must have the resources to run the switch on its own, which means that all supervisor engine resources are duplicated. Identical supervisor engine memory configurations are recommended, but are not required as long as the supervisor engine with the smaller memory configuration is sufficient to run the configured features of the switch. Additionally, each supervisor engine must have its own flash device and console port connections.</p>

Table 1-13 Catalyst 6509-E Switch Features (continued)

Feature	Description
Modules	<ul style="list-style-type: none"> • Supports up to eight Catalyst 6500 series modules. • WS-C6500-SFM and WS-X6500-SFM2 Switch Fabric Modules must be installed in slot 5 or slot 6. <p>Note Mixing WS-C6500-SFM and WS-X6500-SFM2 Switch Fabric Modules in the Catalyst 6509-E chassis is allowed.</p> <ul style="list-style-type: none"> • Some Catalyst 6500 series modules may: <ul style="list-style-type: none"> – Not be supported – Require that you install a Supervisor Engine 720 – Have chassis slot restrictions – Require a specific software release level to operate <p>Note Check your software release notes for specific information on module supported and restrictions.</p>
Backplane bandwidth	<ul style="list-style-type: none"> • 32 GBps shared bus. • 256 GBps switch fabric. • 720 GBps switch fabric.
Clock and VTT modules	<ul style="list-style-type: none"> • Two replaceable clock modules (CLK-7600=) provide clocking signals to the EOBC channel and the switching bus. • Three replaceable voltage termination (VTT) modules (WS-C6K-VTT-E=) provide reference voltage for bus signals.
Fan tray	<ul style="list-style-type: none"> • The chassis supports one hot-swappable fan tray. One fan tray model is available: <ul style="list-style-type: none"> – WS-C6509-E-FAN—846 CFM <p>Note You must install a 2500 W or higher capacity power supply in the chassis to power the high-speed fan tray. The 2500 W power supply can be powered from either 120 VAC or 220 VAC.</p> <p>Note The fan tray contains nine individual fans. The individual fans are not field replaceable; you must replace the fan tray in the event of a fan failure.</p> <ul style="list-style-type: none"> • Fan tray STATUS LED <ul style="list-style-type: none"> – Red—One or more individual fans have failed. – Green—Fan tray is operating normally.

Table 1-13 Catalyst 6509-E Switch Features (continued)

Feature	Description
Power supply	<ul style="list-style-type: none"> • Supports one or two power supplies. The following models are supported: <ul style="list-style-type: none"> – WS-CAC-2500W (2500 W AC-input power supply). – WS-CDC-2500W (2500 W DC-input power supply). – WS-CAC-3000W (3000 W AC-input power supply). – WS-CAC-4000W-US (4000 W AC-input power supply). – WS-CAC-4000W-INT (4000 W AC-input power supply). – PWR-4000-DC (4000 W DC-input power supply). – WS-CAC-6000W (6000 W AC-input power supply). – PWR-6000-DC (6000 W DC-input power supply). – WS-CAC-8700W-E (8700 W AC-input power supply). • Installed power supplies can be of different wattage ratings. Installed power supplies can also be both AC-input, both DC-input, or one AC-input and one DC-input. Power supplies can be configured in either redundant or combined mode. • All Catalyst 6500 series AC-input power supplies require single-phase source AC. Source AC can be out of phase between multiple power supplies or multiple AC-power plugs on the same power supply because all AC power supply inputs are isolated. • Supervisor Engine 2T requires a 3000 W or greater power supply to operate. <p>Note For proper operation of the power supply OUTPUT FAIL LED, systems with single power supplies must be configured with a minimum of one fan tray and one supervisor engine. Systems with dual power supplies must have a minimum configuration of one fan tray, one supervisor engine, and one additional module. Failure to meet these minimum configuration requirements can cause a false power supply output fail signal.</p>

Table 1-14 lists the environmental and physical specifications of the Catalyst 6509-E switch chassis.

Table 1-14 Catalyst 6509-E Switch Specifications

Item	Specification
Environmental	
Temperature, operating	Certified for operation: 32° to 104°F (0° to 40°C) Designed and tested for operation: 32° to 131°F (0° to 55°C) Note The Catalyst 6500 series switches are equipped with internal air temperature sensors that are triggered at 104°F (40°C) generating a minor alarm and at 131°F (55°C) generating a major alarm.
Temperature, nonoperating and storage	Chassis unpackaged: -4° to 149°F (-20° to 65°C) Chassis in protective shipping package: -40° to 158°F (-40° to 70°C)
Thermal transition	0.5°C per minute (hot to cold) 0.33°C per minute (cold to hot)
Humidity (RH), ambient (noncondensing) operating	5% to 90%
Humidity (RH), ambient (noncondensing) nonoperating and storage	5% to 95%
Altitude, operating	Certified for operation: 0 to 6500 ft (0 to 2000 m) Designed and tested for operation: -200 to 10,000 ft (-60 to 3000 m)
Shock and vibration	This switch complies with Network Equipment Building Systems (NEBS) (Zone 4 per GR-63-Core) in the following areas: <ul style="list-style-type: none"> • Earthquake environment and criteria • Office vibration and criteria • Transportation vibration and criteria Shock <ul style="list-style-type: none"> • Operational—5 G 30 ms, half-sine (IEC 68-2-27) • Nonoperational—20 G, 7.5 ms, trapezoidal Vibration Operational—3 Hz to 500 Hz. Power Spectral Density (PSD)—0.0005 G ² /Hz at 10 Hz and 200 Hz. 5 dB/octave roll off at each end. 0.5 hours per axis (1.12 Grms).
Acoustic noise	67 dB. International Organization for Standardization (ISO) 7779: Bystander position operating to an ambient temperature of 86°F (30°C).

Table 1-14 Catalyst 6509-E Switch Specifications (continued)

Item	Specification
Physical characteristics Dimensions (H x W x D) Weight	<ul style="list-style-type: none"> • 24.5 x 17.5 x 18.2 in. (62.2 x 44.5 x 46.0 cm). • Chassis depth including cable guide is 21.64 in. (55.0 cm). • Chassis requires 15 RU¹. • The Catalyst 6509-E switch chassis is designed to install in standard 19-inch equipment racks that meet ANSI/EIA 310-D, IEC 60297, and ETS 300-119 standards. Chassis only: 60 lb (27.3 kg). Chassis fully configured with 1 supervisor engine, 8 switching modules, and 2 power supplies: 190 lb (86.4 kg).
Airflow	WS-C6509-E-FAN—846 CFM Note To maintain proper air circulation through the Catalyst switch chassis, we recommend that you maintain a minimum 6-inch (15 cm) separation between a wall and the chassis air intake or a wall and the chassis air exhaust. You should also allow a minimum separation of 12 inches (30.5 cm) between the hot air exhaust on one chassis and the air intake on another chassis. Failure to maintain adequate air space can cause the chassis to overheat and the system to fail. On Catalyst chassis in which the airflow is from front to back, the chassis may be placed side-by-side.

1. RU = rack units

Catalyst 6509-NEB Switch

The Catalyst 6509-NEB switch is a 9-slot vertical chassis supporting redundant power supplies, redundant supervisor engines, and slots for up to eight modules. The chassis is NEBS L3 compliant. [Figure 1-11](#) shows the Catalyst 6509-NEB switch chassis.

Figure 1-11 Catalyst 6509-NEB Switch

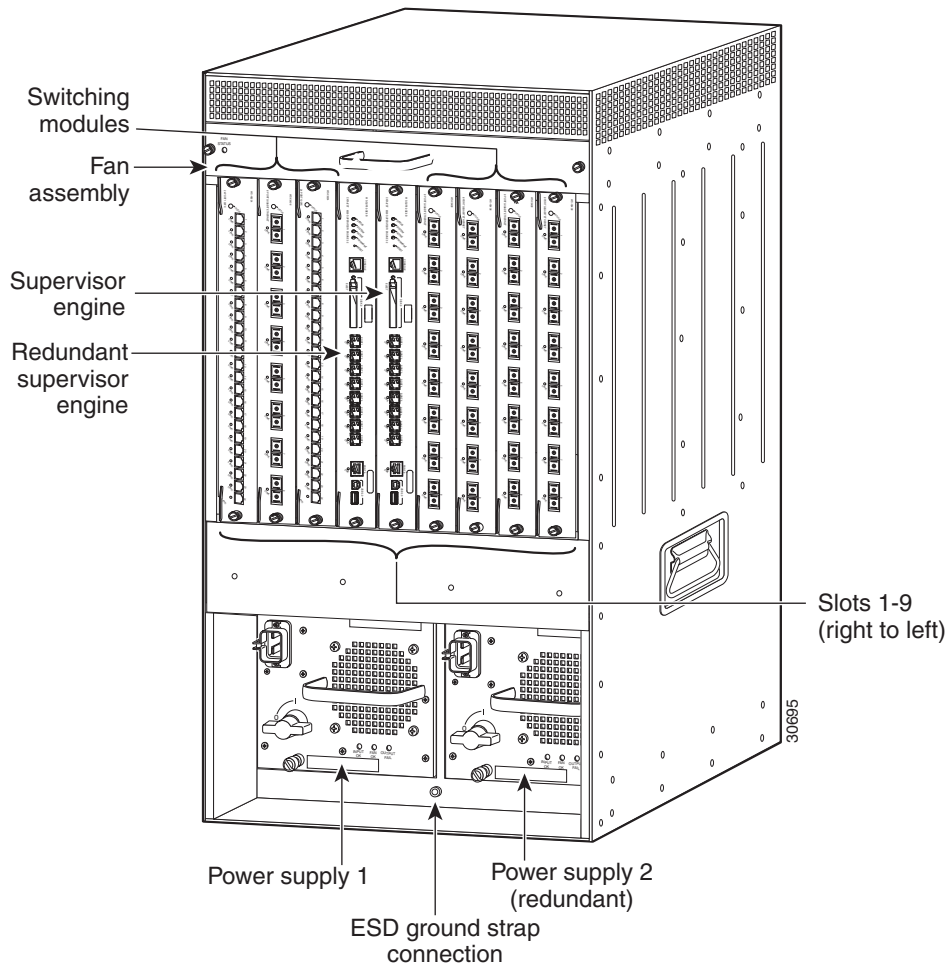

Table 1-15 lists the features of the Catalyst 6509-NEB switch chassis.

Table 1-15 Catalyst 6509-NEB Switch Features

Feature	Features
Chassis	<ul style="list-style-type: none"> • Nine vertical slots. Slots are numbered from 1 (right) to 9 (left).
Supervisor engines	<ul style="list-style-type: none"> • Supports Supervisor Engine 2, Supervisor Engine 32, Supervisor Engine 32 PISA, Supervisor Engine 720, and Supervisor Engine 720-10GE. <p>Note Refer to your software release notes for the minimum software release versions required to support the supervisor engines.</p> <ul style="list-style-type: none"> – Supervisor Engine 2 must be installed in slot 1 or slot 2. – Supervisor Engine 32, Supervisor Engine 32 PISA, Supervisor Engine 720, and Supervisor Engine 720-10GE. must be installed in slot 5 or slot 6. <p>Note Supervisor Engine 32, Supervisor Engine 32 PISA, Supervisor Engine 720, and Supervisor Engine 720-10GE are supported if the WS-6509-NEB-UPGRD kit is installed.</p> <p>Note Slots not occupied by supervisor engines can be used for modules. Check your software release notes for any restrictions on the type of module that can be installed.</p> <ul style="list-style-type: none"> • Supervisor Engine 720 and Supervisor Engine 720-10GE have a built-in switching fabric. Switch Fabric Modules (WS-C6500-SFM and WS-X6500-SFM2) are not supported by Supervisor Engine 720. You cannot install the Switch Fabric Modules and the Supervisor Engine 720 or the Supervisor Engine 720-10GE in the same chassis. • Supervisor Engine 32 and Supervisor Engine 32 PISA do not support the Switch Fabric Modules (WS-C6500-SFM and WS-X6500-SFM2). You cannot install the Switch Fabric Modules and the Supervisor Engine 32 or the Supervisor Engine 32 PISA in the same chassis. • The uplink ports are fully functional on all redundant supervisor engine models when they are in standby mode. <p>Note In systems with redundant supervisor engines, both supervisor engines must be the same model and have the same daughter card configurations. Each supervisor engine must have the resources to run the switch on its own, which means that all supervisor engine resources are duplicated. Identical supervisor engine memory configurations are recommended, but are not required as long as the supervisor engine with the smaller memory configuration is sufficient to run the configured features of the switch. Additionally, each supervisor engine must have its own flash device and console port connections.</p>

Table 1-15 Catalyst 6509-NEB Switch Features (continued)

Feature	Features
Modules	<ul style="list-style-type: none"> • Supports up to eight Catalyst 6500 series modules. • WS-C6500-SFM and WS-X6500-SFM2 Switch Fabric Modules must be installed in slot 5 or slot 6. <p>Note Mixing WS-C6500-SFM and WS-X6500-SFM2 Switch Fabric Modules in the Catalyst 6509-NEB chassis is allowed.</p> <ul style="list-style-type: none"> • Some Catalyst 6500 series modules may: <ul style="list-style-type: none"> – Not be supported – Require that you install a Supervisor Engine 720 – Have chassis slot restrictions – Require a specific software release level to operate <p>Note Check your software release notes for specific information.</p>
Backplane bandwidth	<ul style="list-style-type: none"> • 32 GBps shared bus. • 256 GBps switch fabric. • 720 GBps switch fabric.
Clock and VTT modules	<ul style="list-style-type: none"> • Two replaceable clock modules (WS-C6K-CL=) provide clocking signals to the EOBC channel and the switching bus. • Three replaceable voltage termination (VTT) modules (WS-C6K-VTT=) provide reference voltage for bus signals.

Table 1-15 Catalyst 6509-NEB Switch Features (continued)

Feature	Features
Fan tray	<ul style="list-style-type: none"> • The chassis supports one hot-swappable fan tray. Two fan tray models are available: <ul style="list-style-type: none"> – WS-C6509-NEB-FAN (Standard fan tray—294 CFM). Supports Supervisor Engine 1 and Supervisor Engine 2 only; does not support Supervisor Engine 32, Supervisor Engine 32 PISA, Supervisor Engine 720, or Supervisor Engine 720-10GE. – WS-6509-NEB-UPGRD¹—630 CFM (The high-speed fan tray (WS-C6509-NEB-FAN2) is a part of the upgrade kit). This kit must be installed if you are installing a Supervisor Engine 32 or a Supervisor Engine 720 in the Catalyst 6509-NEB switch. The kit contains a high-speed fan tray, back panel, and power harness. If you are operating the chassis from an AC source, you will also need to order a 3000 W AC-input power supply which has a front panel DC power connector. The upgrade kit fan tray receives 42 VDC power from this front panel DC power connector through a power harness also provided in the upgrade kit. If you are operating the chassis from a DC source, you can power the system with either the 2500 W or 4000 W DC-input power supplies and power the upgrade fan tray from the site source DC. <p>Note Both fan tray models contain nine individual fans. The individual fans are not field replaceable; you must replace the fan tray in the event of a fan failure.</p> <ul style="list-style-type: none"> • Fan tray STATUS LED <ul style="list-style-type: none"> – Red—One or more individual fans have failed. – Green—Fan tray is operating normally.

Table 1-15 Catalyst 6509-NEB Switch Features (continued)

Feature	Features
Power supply	<ul style="list-style-type: none"> • Supports one or two power supplies. The following models are supported: <ul style="list-style-type: none"> – WS-CAC-2500W (2500 W AC-input power supply). – WS-CDC-2500W (2500 W DC-input power supply). – WS-CAC-3000W (3000 W AC-input power supply). – WS-CAC-4000W-US (4000 W AC-input power supply). – WS-CAC-4000W-INT (4000 W AC-input power supply). – PWR-4000-DC (4000 W DC-input power supply). – WS-CAC-6000W (6000 W AC-input power supply). – PWR-6000-DC (6000 W DC-input power supply). – WS-CAC-8700W-E (8700 W AC-input power supply). <p>Note The 6000 W AC-input and DC-input power supplies and the 8700 W AC-input power supply are limited to 4000 W maximum output when installed in the Catalyst 6509-NEB chassis.</p> <ul style="list-style-type: none"> • Installed power supplies can be of different wattage ratings. Installed power supplies can also be both AC-input, both DC-input, or one AC-input and one DC-input. Power supplies can be configured in either redundant or combined mode. • All Catalyst 6500 series AC-input power supplies require single-phase source AC. Source AC can be out of phase between multiple power supplies or multiple AC-power plugs on the same power supply because all AC power supply inputs are isolated. • Single power supplies are installed in the left power supply bay. The second power supply is installed in the right power supply bay. <p>Note For proper operation of the power supply OUTPUT FAIL LED, systems with single power supplies must be configured with a minimum of one fan tray and one supervisor engine. Systems with dual power supplies must have a minimum configuration of one fan tray, one supervisor engine, and one additional module. Failure to meet these minimum configuration requirements can cause a false power supply output fail signal.</p>

1. Refer to the *Catalyst 6509-NEB Switch and Cisco OSR-7609 Router Upgrade Note* for kit installation instructions.

Table 1-16 lists the environmental and physical specifications of the Catalyst 6509-NEB switch chassis.

Table 1-16 Catalyst 6509-NEB Switch Specifications

Item	Specification
Environmental Temperature, operating Temperature, nonoperating and storage Thermal transition Humidity (RH), ambient (noncondensing) operating Humidity (RH), ambient (noncondensing) nonoperating and storage Altitude, operating	Certified for operation: 32° to 104°F (0° to 40°C) Designed and tested for operation: 32° to 131°F (0° to 55°C) Note The Catalyst 6500 series switches are equipped with internal air temperature sensors that are triggered at 104°F (40°C) generating a minor alarm and at 131°F (55°C) generating a major alarm. Chassis unpackaged: -4° to 149°F (-20° to 65°C) Chassis in protective shipping package: -40° to 158°F (-40° to 70°C) 0.5°C per minute (hot to cold) 0.33°C per minute (cold to hot) 5% to 90% 5% to 95% Certified for operation: 0 to 6500 ft (0 to 2000 m) Designed and tested for operation: -200 to 10,000 ft (-60 to 3000 m)
Shock and vibration	This switch complies with Network Equipment Building Systems (NEBS) (Zone 4 per GR-63-Core) in the following areas: <ul style="list-style-type: none"> • Earthquake environment and criteria • Office vibration and criteria • Transportation vibration and criteria Shock <ul style="list-style-type: none"> • Operational—5 G 30 ms, half-sine (IEC 68-2-27) • Nonoperational—20 G, 7.5 ms, trapezoidal Vibration Operational—3 Hz to 500 Hz. Power Spectral Density (PSD)—0.0005 G ² /Hz at 10 Hz and 200 Hz. 5 dB/octave roll off at each end. 0.5 hours per axis (1.12 Grms).
Acoustic noise	56.4 to 75 dB. International Organization for Standardization (ISO) 7779: Bystander position operating to an ambient temperature of 86°F (30°C).

Table 1-16 Catalyst 6509-NEB Switch Specifications (continued)

Item	Specification
Physical characteristics	
Dimensions (H x W x D)	<ul style="list-style-type: none"> 33.3 x 17.2 x 18.1 in. (84.6 x 43.7 x 46.0 cm). Chassis requires 20 RU¹. The Catalyst 6509-NEB switch chassis is designed to install in standard 19-inch equipment racks that meet ANSI/EIA 310-D, IEC 60297, and ETS 300-119 standards.
Weight	<p>Chassis only: 55 lb (24.9 kg). Chassis fully configured with 1 supervisor engine, 8 switching modules, and 2 power supplies: 135 lb (61.2 kg).</p>
Airflow	<ul style="list-style-type: none"> WS-C6509-NEB-FAN (Standard fan tray)—294 CFM Optional high-speed fan tray²—630 CFM <p>Note To maintain proper air circulation through the Catalyst switch chassis, we recommend that you maintain a minimum 6-inch (15 cm) separation between a wall and the chassis air intake or a wall and the chassis air exhaust. You should also allow a minimum separation of 12 inches (30.5 cm) between the hot air exhaust on one chassis and the air intake on another chassis. Failure to maintain adequate air space can cause the chassis to overheat and the system to fail. On Catalyst chassis in which the airflow is from front to back, the chassis may be placed side-by-side.</p>

1. RU = rack units.

2. Part of the WS-6509-NEB-UPGRD kit.

Catalyst 6509-NEB-A Switch

The Catalyst 6509-NEB-A switch is an enhanced version of the Catalyst 6509-NEB switch. The 9-slot vertical chassis supports redundant power supplies, redundant supervisor engines, and slots for up to eight modules. It also supports the Supervisor Engine 720 without any upgrades to the chassis. The Catalyst 6509-NEB-A switch chassis is NEBS L3 compliant. [Figure 1-12](#) shows a front view of the Catalyst 6509-NEB-A switch chassis.

Figure 1-12 Catalyst 6509-NEB-A Switch Chassis

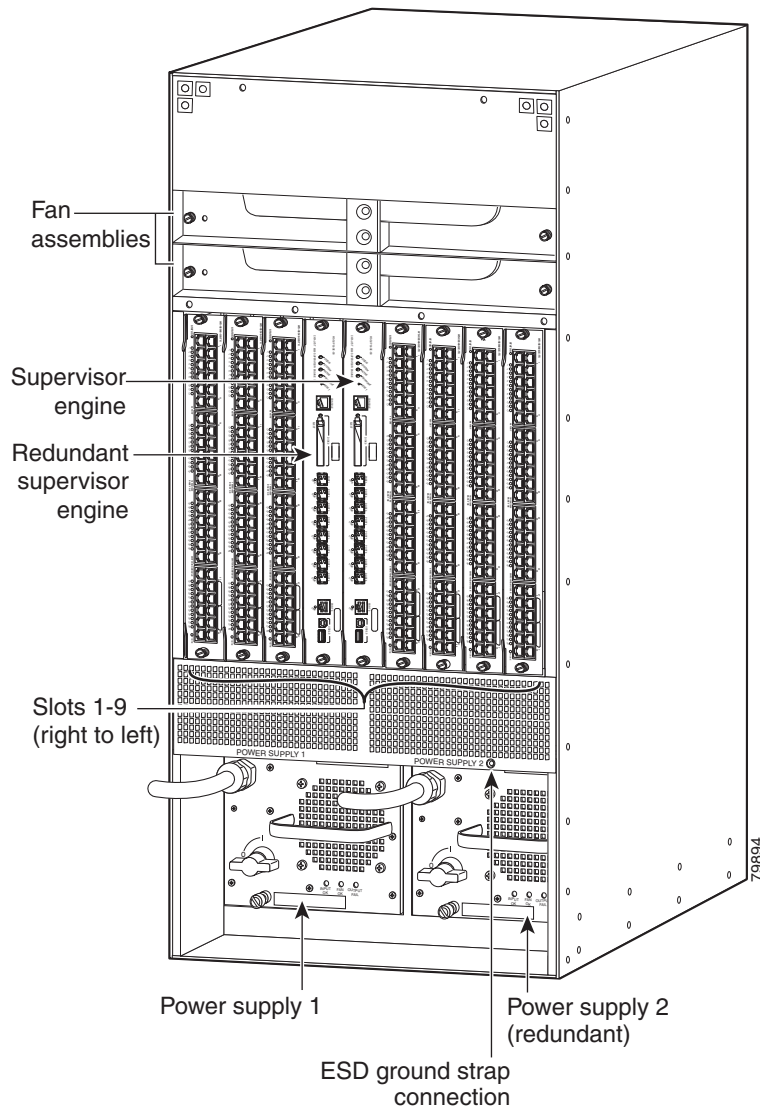

Table 1-17 lists the features of the Catalyst 6509-NEB-A switch chassis.

Table 1-17 Catalyst 6509-NEB-A Switch Features

Feature	Description
Chassis	<ul style="list-style-type: none"> • Nine vertical slots. Slots are numbered from 1 (right) to 9 (left).
Supervisor engines	<ul style="list-style-type: none"> • Supports Supervisor Engine 2, Supervisor Engine 32, Supervisor Engine 32 PISA, Supervisor Engine 720, and Supervisor Engine 720-10GE. <p>Note Refer to your software release notes for the minimum software release versions required to support the supervisor engines.</p> <ul style="list-style-type: none"> – Supervisor Engine 2 must be installed in slot 1 and slot 2. – Supervisor Engine 32, Supervisor Engine 32 PISA, Supervisor Engine 720, and Supervisor Engine 720-10GE must be installed in slot 5 and slot 6. <p>Note Slots not occupied by supervisor engines can be used for modules. Check your software release notes for any restrictions on the type of module that can be installed.</p> <ul style="list-style-type: none"> • Supervisor Engine 720 and Supervisor Engine 720-10GE have a built-in switching fabric. Switch Fabric Modules (WS-C6500-SFM and WS-X6500-SFM2) are not supported by Supervisor Engine 720 and Supervisor Engine 720-10GE. You cannot install the Switch Fabric Modules and the Supervisor Engine 720 or the Supervisor Engine 720-10GE in the same chassis. • Supervisor Engine 32 and Supervisor Engine 32 PISA do not support the Switch Fabric Modules (WS-C6500-SFM and WS-X6500-SFM2). You cannot install the Switch Fabric Modules and the Supervisor Engine 32 or the Supervisor Engine 32 PISA in the same chassis. • The uplink ports are fully functional on all redundant supervisor engine models when they are in standby mode. <p>Note In systems with redundant supervisor engines, both supervisor engines must be the same model and have the same daughter card configurations. Each supervisor engine must have the resources to run the switch on its own, which means that all supervisor engine resources are duplicated. Identical supervisor engine memory configurations are recommended, but are not required as long as the supervisor engine with the smaller memory configuration is sufficient to run the configured features of the switch. Additionally, each supervisor engine must have its own flash device and console port connections.</p>

Table 1-17 Catalyst 6509-NEB-A Switch Features (continued)

Feature	Description
Modules	<ul style="list-style-type: none"> • Supports up to eight Catalyst 6500 series modules. • WS-C6500-SFM and WS-X6500-SFM2 Switch Fabric Modules must be installed in slot 5 or slot 6. <p>Note Mixing WS-C6500-SFM and WS-X6500-SFM2 Switch Fabric Modules in the Catalyst 6509-NEB-A chassis is allowed.</p> <ul style="list-style-type: none"> • Some Catalyst 6500 series modules may: <ul style="list-style-type: none"> – Not be supported – Require that you install a Supervisor Engine 720 – Have chassis slot restrictions – Require a specific software release level to operate <p>Note Check your software release notes for specific information.</p>
Backplane bandwidth	<ul style="list-style-type: none"> • 32 GBps shared bus. • 256 GBps switch fabric. • 720 GBps switch fabric.
Clock and VTT modules	<ul style="list-style-type: none"> • Two replaceable clock modules (CLK-7600=) provide clocking signals to the EOBC channel and the switching bus. • Three replaceable voltage termination (VTT) modules (WS-C6K-VTT=) provide reference voltage for bus signals.
Fan tray	<ul style="list-style-type: none"> • The chassis supports two hot-swappable fan trays. With one fan tray installed, the chassis supports operating temperatures up to 104°F (40°C). With both fan trays installed, the chassis supports operating temperatures up to 131°F (55°C). One fan tray model is available: <ul style="list-style-type: none"> – FAN-MOD-09 (High-speed fan tray—760 CFM). Supports Supervisor Engine 2, Supervisor Engine 32, and Supervisor Engine 720. <p>Note Each fan tray contains four individual fans. The individual fans are not field replaceable; you must replace the fan tray in the event of a fan failure.</p> <ul style="list-style-type: none"> • Fan tray STATUS LED <ul style="list-style-type: none"> – Red—One or more individual fans have failed. – Green—Fan tray is operating normally.

Table 1-17 Catalyst 6509-NEB-A Switch Features (continued)

Feature	Description
Power supply	<ul style="list-style-type: none"> • Supports one or two power supplies. The following models are supported: <ul style="list-style-type: none"> – WS-CAC-2500W (2500 W AC-input power supply). – WS-CDC-2500W (2500 W DC-input power supply). – WS-CAC-3000W (3000 W AC-input power supply). – WS-CAC-4000W-US (4000 W AC-input power supply). – WS-CAC-4000W-INT (4000 W AC-input power supply). – PWR-4000-DC (4000 W DC-input power supply). – WS-CAC-6000W (6000 W AC-input power supply). – PWR-6000-DC (6000 W DC-input power supply). – WS-CAC-8700W-E (8700 W AC-input power supply). <p>Note The 6000 W AC-input and DC-input power supplies and the 8700 W AC-input power supply are limited to 4500 W maximum output when installed in the Catalyst 6509-NEB-A chassis.</p> <ul style="list-style-type: none"> • Installed power supplies can be of different ratings. Installed power supplies can also be both AC-input, both DC-input, or one AC-input and one DC-input. Power supplies can be configured in either redundant or combined mode. • All Catalyst 6500 series AC-input power supplies require single-phase source AC. Source AC can be out of phase between multiple power supplies or multiple AC-power plugs on the same power supply because all AC power supply inputs are isolated. <p>Note For proper operation of the power supply OUTPUT FAIL LED, systems with single power supplies must be configured with a minimum of one fan tray and one supervisor engine. Systems with dual power supplies must have a minimum configuration of one fan tray, one supervisor engine, and one additional module. Failure to meet these minimum configuration requirements can cause a false power supply output fail signal.</p>

Table 1-18 lists the environmental and physical specifications of the Catalyst 6509-NEB-A switch chassis.

Table 1-18 Catalyst 6509-NEB-A Switch Specifications

Item	Specification
Environmental	
Temperature, operating	Certified for operation: 32° to 104°F (0° to 40°C) Designed and tested for operation: 32° to 131°F (0° to 55°C) Note The Catalyst 6500 series switches are equipped with internal air temperature sensors that are triggered at 104°F (40°C) generating a minor alarm and at 131°F (55°C) generating a major alarm.
Temperature, nonoperating and storage	Chassis unpackaged: -4° to 149°F (-20° to 65°C) Chassis in protective shipping package: -40° to 158°F (-40° to 70°C)
Thermal transition	0.5°C per minute (hot to cold) 0.33°C per minute (cold to hot)
Humidity (RH), ambient (noncondensing) operating	5% to 90%
Humidity (RH), ambient (noncondensing) nonoperating and storage	5% to 95%
Altitude, operating	Certified for operation: 0 to 6500 ft (0 to 2000 m) Designed and tested for operation: -200 to 10,000 ft (-60 to 3000 m)
Shock and vibration	This switch complies with Network Equipment Building Systems (NEBS) (Zone 4 per GR-63-Core) in the following areas: <ul style="list-style-type: none"> • Earthquake environment and criteria • Office vibration and criteria • Transportation vibration and criteria Shock <ul style="list-style-type: none"> • Operational—5 G 30 ms, half-sine (IEC 68-2-27) • Nonoperational—20 G, 7.5 ms, trapezoidal Vibration <ul style="list-style-type: none"> Operational—3 Hz to 500 Hz. Power Spectral Density (PSD)—0.0005 G²/Hz at 10 Hz and 200 Hz. 5 dB/octave roll off at each end. 0.5 hours per axis (1.12 Grms).
Acoustic noise	67 to 77 dB. International Organization for Standardization (ISO) 7779: Bystander position operating to an ambient temperature of 86°F (30°C).

Table 1-18 Catalyst 6509-NEB-A Switch Specifications (continued)

Item	Specification
Physical characteristics Dimensions (H x W x D) Weight	<ul style="list-style-type: none"> • 36.65 x 17.20 x 20.32 in. (93.09 x 43.68 x 51.61 cm). • Chassis requires 21 RU¹. • The Catalyst 6509-NEB-A switch chassis is designed to install in standard 19-inch equipment racks that meet ANSI/EIA 310-D, IEC 60297, and ETS 300-119 standards. Chassis only: 121 lb (54.9 kg). Chassis fully configured with 1 supervisor engine, 8 modules, 2 AC-input power supplies: 270 lb (122.47 kg).
Airflow	FAN-MOD-09 (High-speed fan tray)—760 CFM Note To maintain proper air circulation through the Catalyst switch chassis, we recommend that you maintain a minimum 6-inch (15 cm) separation between a wall and the chassis air intake or a wall and the chassis air exhaust. You should also allow a minimum separation of 12 inches (30.5 cm) between the hot air exhaust on one chassis and the air intake on another chassis. Failure to maintain adequate air space can cause the chassis to overheat and the system to fail. On Catalyst chassis in which the airflow is from front to back, the chassis may be placed side-by-side.

1. RU = rack units

Catalyst 6509-V-E Switch

The Catalyst 6509-V-E switch is an enhanced version of the Catalyst 6509-NEB-A switch. The 9-slot vertical chassis supports redundant power supplies, redundant supervisor engines, redundant fan trays, and slots for up to eight modules. It also supports a greater power capacity per slot than the Catalyst 6509-NEB-A switch chassis. The Catalyst 6509-V-E switch chassis is NEBS L3 compliant. [Figure 1-13](#) shows a front view of the Catalyst 6509-V-E switch chassis.

Figure 1-13 Catalyst 6509-V-E Switch Chassis

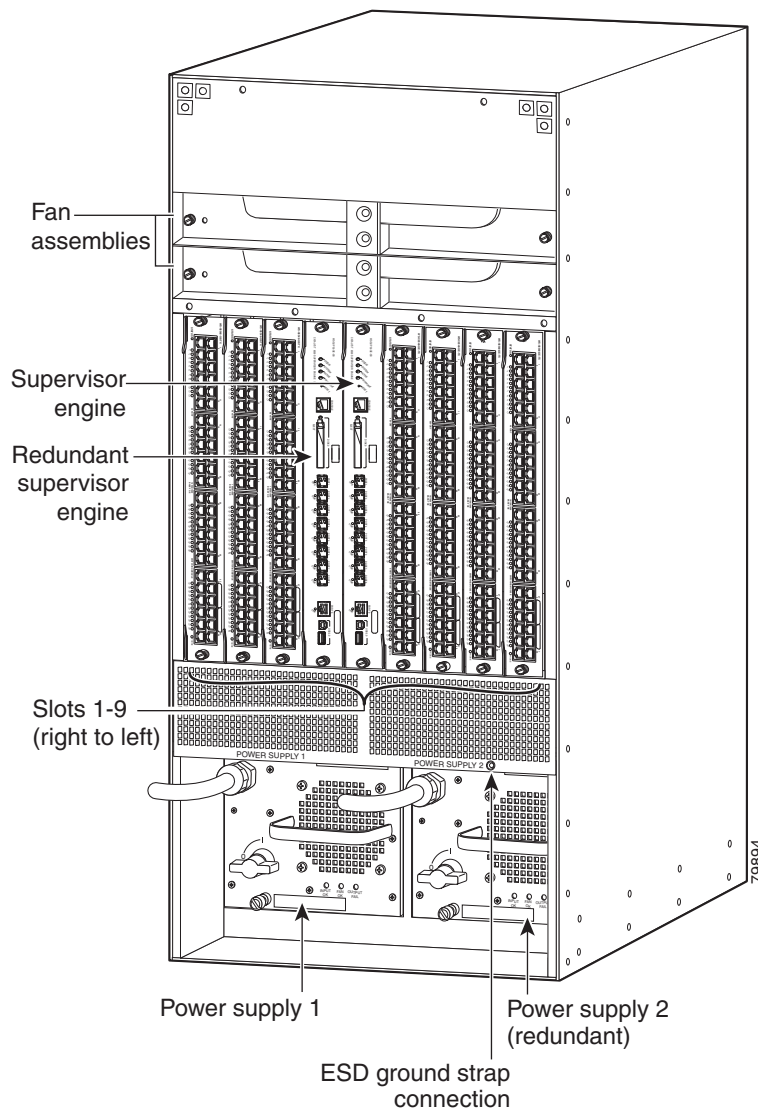

Table 1-19 lists the features of the Catalyst 6509-V-E switch chassis.

Table 1-19 Catalyst 6509-V-E Switch Features

Feature	Description
Chassis	<ul style="list-style-type: none"> Nine vertical slots. Slots are numbered from 1 (right) to 9 (left).
Supervisor engines	<ul style="list-style-type: none"> Supports Supervisor Engine 32, Supervisor Engine 32 PISA, Supervisor Engine 720, Supervisor Engine 720-10GE, and Supervisor Engine 2T. <p>Note Refer to your software release notes for the minimum software release versions required to support the supervisor engines.</p> <ul style="list-style-type: none"> Supervisor Engine 32, Supervisor Engine 32 PISA, Supervisor Engine 720, Supervisor Engine 720-10GE, and Supervisor Engine 2T must be installed in slot 5 and slot 6. <p>Note Slots not occupied by supervisor engines can be used for modules. Check your software release notes for any restrictions on the type of module that can be installed.</p> <ul style="list-style-type: none"> Supervisor Engine 720, Supervisor Engine 720-10GE, and Supervisor Engine 2T have a built-in switching fabric. Switch Fabric Modules are not supported. Supervisor Engine 32 and Supervisor Engine 32 PISA do not support the Switch Fabric Modules (WS-C6500-SFM and WS-X6500-SFM2). The uplink ports are fully functional on all redundant supervisor engine models when they are in standby mode. <p>Note In systems with redundant supervisor engines, both supervisor engines must be the same model and have the same daughter card configurations. Each supervisor engine must have the resources to run the switch on its own, which means that all supervisor engine resources are duplicated. Identical supervisor engine memory configurations are recommended, but are not required as long as the supervisor engine with the smaller memory configuration is sufficient to run the configured features of the switch. Additionally, each supervisor engine must have its own flash device and console port connections.</p>
Modules	<ul style="list-style-type: none"> Supports up to eight Catalyst 6500 series modules. Some Catalyst 6500 series modules may: <ul style="list-style-type: none"> Not be supported Require that you install a Supervisor Engine 720 Have chassis slot restrictions Require a specific software release level to operate <p>Note Check your software release notes for specific information on supported modules and restrictions.</p>
Backplane bandwidth	<ul style="list-style-type: none"> 32 GBps shared bus. 720 GBps switch fabric.

Table 1-19 Catalyst 6509-V-E Switch Features (continued)

Feature	Description
Clock and VTT modules	<ul style="list-style-type: none"> • Two replaceable clock modules (CLK-7600=) provide clocking signals to the EOBC channel and the switching bus. • Three replaceable voltage termination (VTT) modules (WS-C6K-VTT=) provide reference voltage for bus signals.
Fan tray	<ul style="list-style-type: none"> • The chassis supports either one or two hot-swappable fan trays. With only one fan tray installed, the chassis supports operating temperatures up to 104°F (40°C). With two fan trays installed, the chassis supports operating temperatures up to 131°F (55°C). One fan tray model is available: <ul style="list-style-type: none"> – WS-C6509-V-E-FAN (High-speed fan tray—760 CFM). Supports Supervisor Engine 32, and Supervisor Engine 720. <p>Note Each fan tray contains four individual fans. The individual fans are not field replaceable; you must replace the fan tray in the event of a fan failure.</p> <p>Note Two fan trays are shipped as the chassis default configuration.</p> <ul style="list-style-type: none"> • Fan tray STATUS LED <ul style="list-style-type: none"> – Red—One or more individual fans have failed. – Green—Fan tray is operating normally.

Table 1-19 Catalyst 6509-V-E Switch Features (continued)

Feature	Description
Power supply	<ul style="list-style-type: none"> • Supports one or two power supplies. The following models are supported: <ul style="list-style-type: none"> – WS-CAC-2500W (2500 W AC-input power supply). – WS-CDC-2500W (2500 W DC-input power supply). – WS-CAC-3000W (3000 W AC-input power supply). – WS-CAC-4000W-US (4000 W AC-input power supply). – WS-CAC-4000W-INT (4000 W AC-input power supply). – PWR-4000-DC (4000 W DC-input power supply). – WS-CAC-6000W (6000 W AC-input power supply). – PWR-6000-DC (6000 W DC-input power supply). – WS-CAC-8700W-E (8700 W AC-input power supply). • Installed power supplies can be of different ratings. Installed power supplies can also be both AC-input, both DC-input, or one AC-input and one DC-input. Power supplies can be configured in either redundant or combined mode. • All Catalyst 6500 series AC-input power supplies require single-phase source AC. Source AC can be out of phase between multiple power supplies or multiple AC-power plugs on the same power supply because all AC power supply inputs are isolated. • Supervisor Engine 2T requires a 3000 W or greater power supply to operate. <p>Note For proper operation of the power supply OUTPUT FAIL LED, systems with single power supplies must be configured with a minimum of one fan tray and one supervisor engine. Systems with dual power supplies must have a minimum configuration of one fan tray, one supervisor engine, and one additional module. Failure to meet these minimum configuration requirements can cause a false power supply output fail signal.</p>

Table 1-20 lists the environmental and physical specifications of the Catalyst 6509-V-E switch chassis.

Table 1-20 Catalyst 6509-V-E Switch Specifications

Item	Specification
Environmental Temperature, operating Temperature, nonoperating and storage Thermal transition Humidity (RH), ambient (noncondensing) operating Humidity (RH), ambient (noncondensing) nonoperating and storage Altitude, operating	Certified for operation: 32° to 104°F (0° to 40°C) Designed and tested for operation: 32° to 131°F (0° to 55°C) Note The Catalyst 6500 series switches are equipped with internal air temperature sensors that are triggered at 104°F (40°C) generating a minor alarm and at 131°F (55°C) generating a major alarm. Chassis unpackaged: -4° to 149°F (-20° to 65°C) Chassis in protective shipping package: -40° to 158°F (-40° to 70°C) 0.5°C per minute (hot to cold) 0.33°C per minute (cold to hot) 5% to 90% 5% to 95% Certified for operation: 0 to 6500 ft (0 to 2000 m) Designed and tested for operation: -200 to 10,000 ft (-60 to 3000 m)
Shock and vibration	This switch complies with Network Equipment Building Systems (NEBS) (Zone 4 per GR-63-Core) in the following areas: <ul style="list-style-type: none"> • Earthquake environment and criteria • Office vibration and criteria • Transportation vibration and criteria Shock <ul style="list-style-type: none"> • Operational—5 G 30 ms, half-sine (IEC 68-2-27) • Nonoperational—20 G, 7.5 ms, trapezoidal Vibration Operational—3 Hz to 500 Hz. Power Spectral Density (PSD)—0.0005 G ² /Hz at 10 Hz and 200 Hz. 5 dB/octave roll off at each end. 0.5 hours per axis (1.12 Grms).
Acoustic noise	67 to 77 dB. International Organization for Standardization (ISO) 7779: Bystander position operating to an ambient temperature of 86°F (30°C).

Table 1-20 Catalyst 6509-V-E Switch Specifications (continued)

Item	Specification
Physical characteristics Dimensions (H x W x D) Weight	<ul style="list-style-type: none"> • 36.65 x 17.20 x 20.7 in. (93.3 x 43.1 x 53.3 cm). • Chassis requires 21 RU¹. • The Catalyst 6509-V-E switch chassis is designed to install in standard 19-inch equipment racks that meet ANSI/EIA 310-D, IEC 60297, and ETS 300-119 standards. Chassis only: 121 lb (54.9 kg). Chassis fully configured with 1 supervisor engine, 8 modules, 2 AC-input power supplies: 270 lb (122.47 kg).
Airflow	WS-C6509-V-E-FAN (High-speed fan tray)—760 CFM Note To maintain proper air circulation through the Catalyst switch chassis, we recommend that you maintain a minimum 6-inch (15 cm) separation between a wall and the chassis air intake or a wall and the chassis air exhaust. You should also allow a minimum separation of 12 inches (30.5 cm) between the hot air exhaust on one chassis and the air intake on another chassis. Failure to maintain adequate air space can cause the chassis to overheat and the system to fail. On Catalyst chassis in which the airflow is from front to back, the chassis may be placed side-by-side.

1. RU = rack units

Catalyst 6513 Switch

The Catalyst 6513 switch is a 13-slot horizontal chassis supporting redundant power supplies, redundant supervisor engines, and slots for up to twelve modules. The chassis is NEBS L3 compliant. [Figure 1-14](#) shows a front view of the Catalyst 6513 switch chassis.

Figure 1-14 Catalyst 6513 Switch

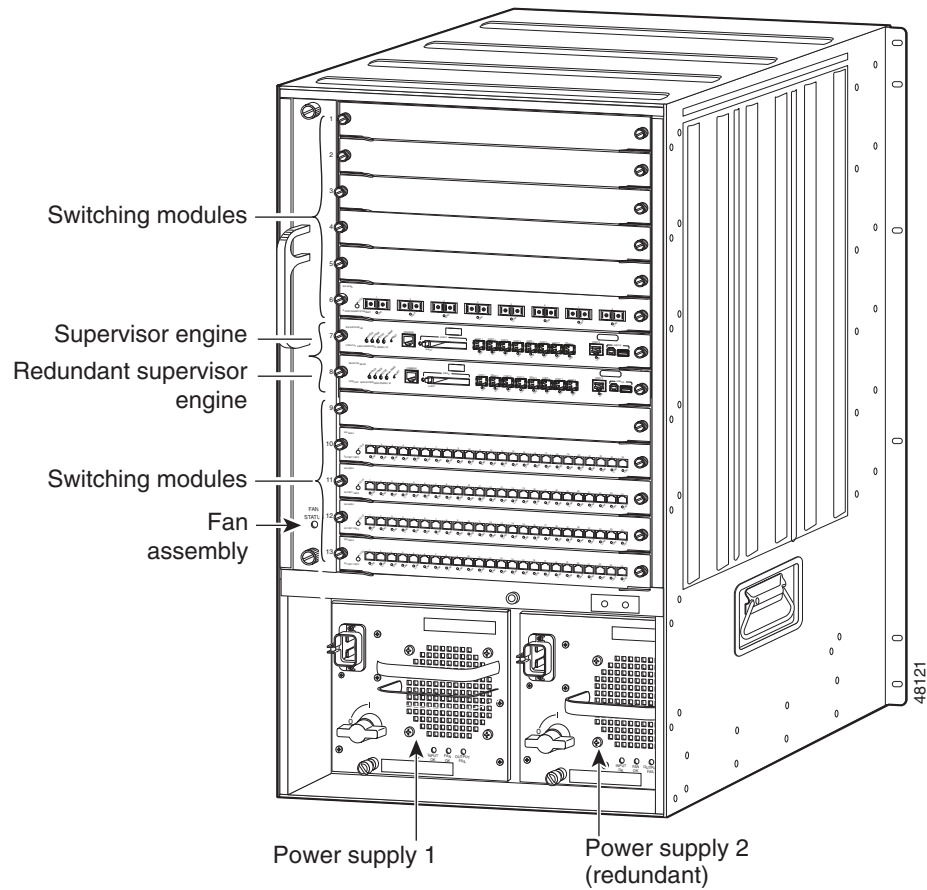

Table 1-21 lists the features of the Catalyst 6513 switch chassis.

Table 1-21 Catalyst 6513 Switch Features

Feature	Description
Chassis	<ul style="list-style-type: none"> Thirteen horizontal slots. Slots are numbered from (1) top to (13) bottom.
Supervisor engines	<ul style="list-style-type: none"> Supports Supervisor Engine 2, Supervisor Engine 32, Supervisor Engine 32 PISA, Supervisor Engine 720, and Supervisor Engine 720-10GE. <p>Note Refer to your software release notes for the minimum software release versions required to support the supervisor engines.</p> <ul style="list-style-type: none"> Supervisor Engine 2 must be installed in slot 1 and slot 2. Supervisor Engine 32, Supervisor Engine 32 PISA, Supervisor Engine 720, and Supervisor Engine 720-10GE must be installed in slot 7 and slot 8. <p>Note Slots not occupied by supervisor engines can be used for modules. Check your software release notes for any restrictions on the type of module that can be installed.</p> <ul style="list-style-type: none"> Supervisor Engine 32, Supervisor Engine 32 PISA, Supervisor Engine 720, and Supervisor Engine 720-10GE require that you install the high-speed fan tray (WS-C6K-13SLT-FAN2) be installed in the chassis. You must also install a 2500 W or higher capacity power supply in the chassis to power the high-speed fan tray. Supervisor Engine 720 and Supervisor Engine 720-10GE have a built-in switching fabric. Switch Fabric Modules (WS-C6500-SFM and WS-X6500-SFM2) are not supported by Supervisor Engine 720 and Supervisor Engine 720-10GE. Supervisor Engine 32 and Supervisor Engine 32 PISA do not support the Switch Fabric Modules (WS-C6500-SFM and WS-X6500-SFM2). The uplink ports are fully functional on all redundant supervisor engine models when they are in standby mode. <p>Note In systems with redundant supervisor engines, both supervisor engines must be the same model and have the same daughter card configurations. Each supervisor engine must have the resources to run the switch on its own, which means that all supervisor engine resources are duplicated. Identical supervisor engine memory configurations are recommended, but are not required as long as the supervisor engine with the smaller memory configuration is sufficient to run the configured features of the switch. Additionally, each supervisor engine must have its own flash device and console port connections.</p>

Table 1-21 Catalyst 6513 Switch Features (continued)

Feature	Description
Modules	<ul style="list-style-type: none"> • Supports up to 12 Catalyst 6500 series modules. • When using a Supervisor Engine 2 the WS-C6500-SFM and WS-X6500-SFM2 Switch Fabric Modules must be installed in slot 7 or slot 8. <p>Note Mixing WS-C6500-SFM and WS-X6500-SFM2 Switch Fabric Modules is not allowed in the Catalyst 6513 chassis.</p> <ul style="list-style-type: none"> • Slots 1–8 support a single fabric channel; slots 9–13 support dual fabric channels. • The following modules are supported only in chassis slots 9–13 and do not power up when they are installed in the other chassis slots: <ul style="list-style-type: none"> – WS-X6748-SFP – WS-X6748-GE-TX – WS-X6704-10GE – WS-X6708-10GE – WS-X6716-10GE – WS-X6816-GBIC – WS-SVC-WISM-1-K9 <p>Note The WS-X6724-SFP Ethernet module has a single fabric channel and is supported in all Catalyst 6513 switch chassis slots.</p> <ul style="list-style-type: none"> • Check your software release notes for specific information on module support. Some Catalyst 6500 series modules may: <ul style="list-style-type: none"> – Not be supported – Require that you install a Supervisor Engine 720 – Have chassis slot restrictions – Require a specific software release level to operate
Backplane bandwidth	<ul style="list-style-type: none"> • 32 GBps shared bus. • 256 GBps switch fabric. • 720 GBps switch fabric.
Clock and VTT module	<ul style="list-style-type: none"> • Two replaceable clock modules (WS-C6513-CL=) provide clocking signals to the EOBC channel and the switching bus. • Three replaceable voltage termination (VTT) modules (WS-C6K-VTT=) provide reference voltage for bus signals.

Table 1-21 Catalyst 6513 Switch Features (continued)

Feature	Description
Fan tray	<ul style="list-style-type: none"> • The chassis supports one hot-swappable fan tray. Two fan tray models are available: <ul style="list-style-type: none"> – WS-C6K-13SLOT-FAN (Standard fan tray—641 CFM). Supports Supervisor Engine 2 only; does not provide sufficient cooling for the Supervisor Engine 32, Supervisor Engine 32 PISA, Supervisor Engine 720, or the Supervisor Engine 720-10GE. – WS-C6K-13SLT-FAN2 (Optional high-speed fan tray—1090 CFM). Provides sufficient cooling for all supervisor engine types. <p>Note You must install a high-speed fan tray when using a Supervisor Engine 32 or a Supervisor Engine 720. You must install a 2500 W or higher capacity power supply in the chassis to power the high-speed fan tray. The 2500 W power supply can be powered from either 120 VAC or 220 VAC.</p> <p>Note Both fan tray models contain 15 individual fans. The individual fans are not field replaceable; you must replace the fan tray in the event of a fan failure.</p> <ul style="list-style-type: none"> • Fan tray STATUS LED <ul style="list-style-type: none"> – Red—One or more individual fans have failed. – Green—Fan tray is operating normally.

Table 1-21 Catalyst 6513 Switch Features (continued)

Feature	Description
Power supply	<ul style="list-style-type: none"> • Supports one or two power supplies. The following models are supported: <ul style="list-style-type: none"> – WS-CAC-2500W (2500 W AC-input power supply). – WS-CDC-2500W (2500 W DC-input power supply). – WS-CAC-3000W (3000 W AC-input power supply). – WS-CAC-4000W-US (4000 W AC-input power supply). – WS-CAC-4000W-INT (4000 W AC-input power supply). – PWR-4000-DC (4000 W DC-input power supply). – WS-CAC-6000W (6000 W AC-input power supply). – PWR-6000-DC (6000 W DC-input power supply). – WS-CAC-8700W-E (8700 W AC-input power supply). <p>Note The 8700 W power supply is limited to 6000 W maximum output when installed in the Catalyst 6513 switch chassis.</p> <ul style="list-style-type: none"> • Installed power supplies can be of different ratings. Installed power supplies can also be both AC-input, both DC-input, or one AC-input and one DC-input. Power supplies can be configured in either redundant or combined mode. • All Catalyst 6500 series AC-input power supplies require single-phase source AC. Source AC can be out of phase between multiple power supplies or multiple AC-power plugs on the same power supply because all AC power supply inputs are isolated. • You must install a 2500 W or higher capacity power supply when using the Supervisor Engine 32 or the Supervisor Engine 720 and the high-speed fan tray. <p>Note For proper operation of the power supply OUTPUT FAIL LED, systems with single power supplies must be configured with a minimum of one fan tray and one supervisor engine. Systems with dual power supplies must have a minimum configuration of one fan tray, one supervisor engine, and one additional module. Failure to meet these minimum configuration requirements can cause a false power supply output fail signal.</p>

Table 1-22 lists the environmental and physical specifications of the Catalyst 6513 switch chassis.

Table 1-22 Catalyst 6513 Switch Specifications

Item	Specification
Environmental	
Temperature, operating	Certified for operation: 32° to 104°F (0° to 40°C) Designed and tested for operation: 32° to 131°F (0° to 55°C) Note The Catalyst 6500 series switches are equipped with internal air temperature sensors that are triggered at 104°F (40°C) generating a minor alarm and at 131°F (55°C) generating a major alarm.
Temperature, nonoperating and storage	Chassis unpackaged: -4° to 149°F (-20° to 65°C) Chassis in protective shipping package: -40° to 158°F (-40° to 70°C)
Thermal transition	0.5°C per minute (hot to cold) 0.33°C per minute (cold to hot)
Humidity (RH), ambient (noncondensing) operating	5% to 90%
Humidity (RH), ambient (noncondensing) nonoperating and storage	5% to 95%
Altitude, operating	Certified for operation: 0 to 6500 ft (0 to 2000 m) Designed and tested for operation: -200 to 10,000 ft (-60 to 3000 m)
Shock and vibration	This switch complies with Network Equipment Building Systems (NEBS) (Zone 4 per GR-63-Core) in the following areas: <ul style="list-style-type: none"> • Earthquake environment and criteria • Office vibration and criteria • Transportation vibration and criteria Shock <ul style="list-style-type: none"> • Operational—5 G 30 ms, half-sine (IEC 68-2-27) • Nonoperational—20 G, 7.5 ms, trapezoidal Vibration Operational—3 Hz to 500 Hz. Power Spectral Density (PSD)—0.0005 G ² /Hz at 10 Hz and 200 Hz. 5 dB/octave roll off at each end. 0.5 hours per axis (1.12 Grms).
Acoustic noise	61.4 to 77 dB. International Organization for Standardization (ISO) 7779: Bystander position operating to an ambient temperature of 86°F (30°C).

Table 1-22 Catalyst 6513 Switch Specifications (continued)

Item	Specification
Physical characteristics	
Dimensions (H x W x D)	<ul style="list-style-type: none"> • 33.3 x 17.3 x 18.1 in. (84.6 x 43.7 x 46.0 cm). • Chassis requires 20 RU¹. • The Catalyst 6513 switch chassis is designed to install in standard 19-inch equipment racks that meet ANSI/EIA 310-D, IEC 60297, and ETS 300-119 standards.
Weight	Chassis fully configured with 2 supervisor engines, 11 switching modules, and 2 power supplies: 280 lb (127 kg).
Airflow	<ul style="list-style-type: none"> • WS-C6K-13SLOT-FAN (Standard fan tray)—641 CFM • WS-C6K-13SLT-FAN2 (Optional high-speed fan tray)—1090 CFM <p>Note To maintain proper air circulation through the Catalyst switch chassis, we recommend that you maintain a minimum 6-inch (15 cm) separation between a wall and the chassis air intake or a wall and the chassis air exhaust. You should also allow a minimum separation of 12 inches (30.5 cm) between the hot air exhaust on one chassis and the air intake on another chassis. Failure to maintain adequate air space can cause the chassis to overheat and the system to fail. On Catalyst chassis in which the airflow is from front to back, the chassis may be placed side-by-side.</p>

1. RU = rack units

Catalyst 6513-E Switch

The Catalyst 6513-E switch is a 13-slot horizontal chassis supporting redundant power supplies, redundant supervisor engines, and slots for up to twelve modules. The chassis is NEBS L3 compliant. [Figure 1-15](#) shows a front view of the Catalyst 6513-E switch chassis.

Figure 1-15 Catalyst 6513-E Switch

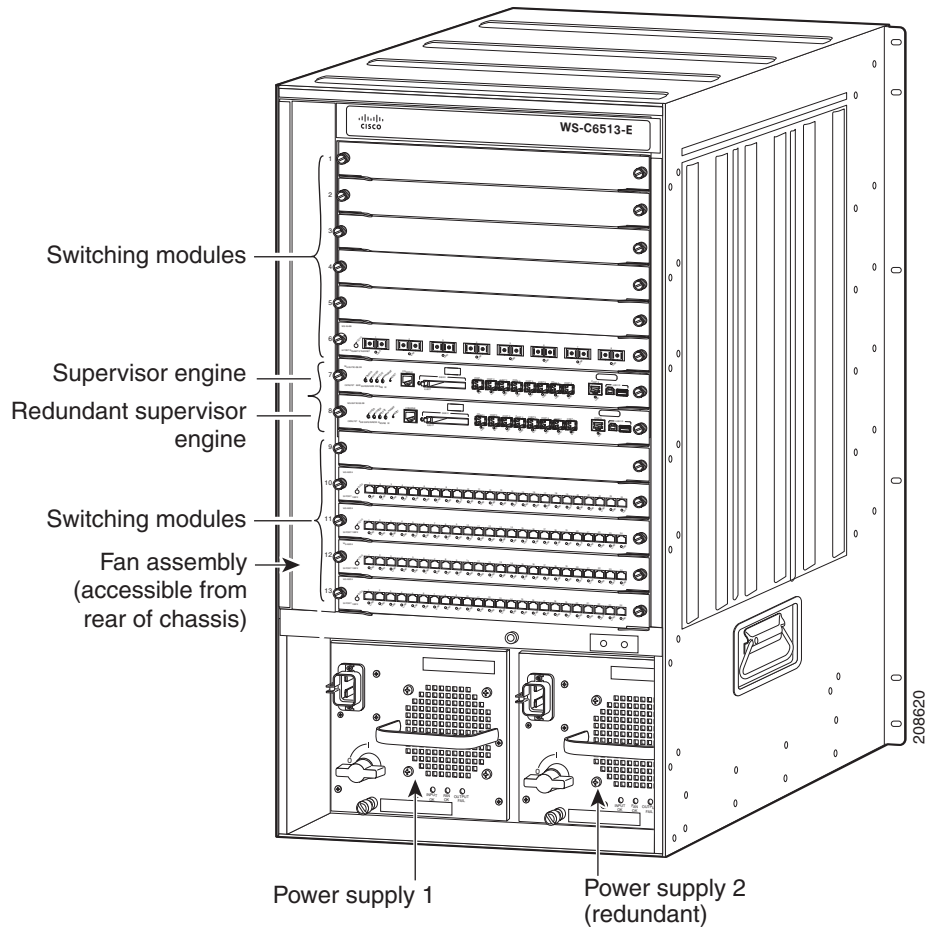

Table 1-23 lists the features of the Catalyst 6513-E switch chassis.

Table 1-23 Catalyst 6513-E Switch Features

Feature	Description
Chassis	<ul style="list-style-type: none"> • Thirteen horizontal slots. Slots are numbered from (1) top to (13) bottom.
Supervisor engines	<ul style="list-style-type: none"> • Supports Supervisor Engine 32, Supervisor Engine 720, Supervisor Engine 720-10GE, and Supervisor Engine 2T. <p>Note Refer to your software release notes for the minimum software release versions required to support the supervisor engines.</p> <ul style="list-style-type: none"> – Supervisor Engine 32, Supervisor Engine 720, Supervisor Engine 720-10GE, and Supervisor Engine 2T must be installed in slot 7 and slot 8. <p>Note Slots not occupied by supervisor engines can be used for modules. Check your software release notes for any restrictions on the type of module that can be installed.</p> <ul style="list-style-type: none"> • Supervisor Engine 720, Supervisor Engine 720-10GE, and Supervisor Engine 2T have a built-in switching fabric. Switch Fabric Modules (WS-C6500-SFM and WS-X6500-SFM2) are not supported. • Supervisor Engine 32 does not support the Switch Fabric Modules (WS-C6500-SFM and WS-X6500-SFM2). • The uplink ports are fully functional on all redundant supervisor engine models when they are in standby mode. <p>Note In systems with redundant supervisor engines, both supervisor engines must be the same model and have the same daughter card configurations. Each supervisor engine must have the resources to run the switch on its own, which means that all supervisor engine resources are duplicated. Identical supervisor engine memory configurations are recommended, but are not required as long as the supervisor engine with the smaller memory configuration is sufficient to run the configured features of the switch. Additionally, each supervisor engine must have its own flash device and console port connections.</p>
Modules	<ul style="list-style-type: none"> • Supports up to 12 Catalyst 6500 series modules. • Slots 1–13 support dual fabric channels. • Check your software release notes for specific information on module support. Some Catalyst 6500 series modules may: <ul style="list-style-type: none"> – Not be supported – Require that you install a specific supervisor engine – Have chassis slot restrictions – Require a specific software release level to operate
Backplane bandwidth	<ul style="list-style-type: none"> • 2 Tbps system bandwidth • 80 Gbps per slot for all thirteen slots

Table 1-23 Catalyst 6513-E Switch Features (continued)

Feature	Description
Clock and VTT module	<ul style="list-style-type: none"> • Two clock modules provide clocking signals to the EOBC channel and the switching bus. • Three voltage termination (VTT) modules provide reference voltage for bus signals.
Fan tray	<ul style="list-style-type: none"> • The chassis supports one hot-swappable fan tray. One fan tray model is available: <ul style="list-style-type: none"> – WS-C6513-E-FAN(=)—1755 CFM <p>Note The fan tray contains 15 individual fans. The individual fans are not field replaceable; you must replace the fan tray in the event of a fan failure.</p> <ul style="list-style-type: none"> • The Catalyst 6513-E fan tray is accessible only from the rear of the chassis. • Fan tray FAN STATUS LEDs (two LEDs: one located on the front of the chassis and one located on the fan tray at the rear of the chassis) <ul style="list-style-type: none"> – Red—One or more individual fans have failed. – Green—Fan tray is operating normally.

Table 1-23 Catalyst 6513-E Switch Features (continued)

Feature	Description
Power supply	<ul style="list-style-type: none"> • Supports one or two power supplies. The following models are supported: <ul style="list-style-type: none"> – WS-CDC-2500W (2500 W DC-input power supply). – WS-CAC-3000W (3000 W AC-input power supply). – WS-CAC-4000W-US (4000 W AC-input power supply). – WS-CAC-4000W-INT (4000 W AC-input power supply). – PWR-4000-DC (4000 W DC-input power supply). – WS-CAC-6000W (6000 W AC-input power supply). – PWR-6000-DC (6000 W DC-input power supply). – WS-CAC-8700W-E (8700 W AC-input power supply). • Installed power supplies can be of different ratings. Installed power supplies can also be both AC-input, both DC-input, or one AC-input and one DC-input. Power supplies can be configured in either redundant or combined mode. • All Catalyst 6500 series AC-input power supplies require single-phase source AC. Source AC can be out of phase between multiple power supplies or multiple AC-power plugs on the same power supply because all AC power supply inputs are isolated. • Supervisor Engine 2T requires a 3000 W or greater power supply to operate. <p>Note For proper operation of the power supply OUTPUT FAIL LED, systems with single power supplies must be configured with a minimum of one fan tray and one supervisor engine. Systems with dual power supplies must have a minimum configuration of one fan tray, one supervisor engine, and one additional module. Failure to meet these minimum configuration requirements can cause a false power supply output fail signal.</p>

Table 1-24 lists the environmental and physical specifications of the Catalyst 6513-E switch chassis.

Table 1-24 Catalyst 6513-E Switch Specifications

Item	Specification
Environmental	
Temperature, operating	Certified for operation: 32° to 104°F (0° to 40°C) Designed and tested for operation: 32° to 131°F (0° to 55°C) Note The Catalyst 6500 series switches are equipped with internal air temperature sensors that are triggered at 104°F (40°C) generating a minor alarm and at 131°F (55°C) generating a major alarm.
Temperature, nonoperating and storage	Chassis unpackaged: -4° to 149°F (-20° to 65°C) Chassis in protective shipping package: -40° to 158°F (-40° to 70°C)
Thermal transition	0.5°C per minute (hot to cold) 0.33°C per minute (cold to hot)
Humidity (RH), ambient (noncondensing) operating	5% to 90%
Humidity (RH), ambient (noncondensing) nonoperating and storage	5% to 95%
Altitude, operating	Certified for operation: 0 to 6500 ft (0 to 2000 m) Designed and tested for operation: -200 to 10,000 ft (-60 to 3000 m)
Shock and vibration	This switch complies with Network Equipment Building Systems (NEBS) (Zone 4 per GR-63-Core) in the following areas: <ul style="list-style-type: none"> • Earthquake environment and criteria • Office vibration and criteria • Transportation vibration and criteria Shock <ul style="list-style-type: none"> • Operational—5 G 30 ms, half-sine (IEC 68-2-27) • Nonoperational—20 G, 7.5 ms, trapezoidal Vibration Operational—3 Hz to 500 Hz. Power Spectral Density (PSD)—0.0005 G ² /Hz at 10 Hz and 200 Hz. 5 dB/octave roll off at each end. 0.5 hours per axis (1.12 Grms).
Acoustic noise	61.4 to 77 dB. International Organization for Standardization (ISO) 7779: Bystander position operating to an ambient temperature of 86°F (30°C).

Table 1-24 Catalyst 6513-E Switch Specifications (continued)

Item	Specification
Physical characteristics Dimensions (H x W x D) Weight	<ul style="list-style-type: none"> • 33.3 x 17.3 x 18.1 in. (84.6 x 43.9 x 46.0 cm). • Chassis requires 20 RU¹. • The Catalyst 6513-E switch chassis is designed to install in standard 19-inch equipment racks that meet ANSI/EIA 310-D, IEC 60297, and ETS 300-119 standards. Chassis fully configured with 2 supervisor engines, 11 switching modules, and 2 power supplies: 280 lb (127 kg). Empty chassis weight: 102 lb (46.3 kg)
Airflow	<ul style="list-style-type: none"> • WS-C6500-E-FAN (Standard fan tray)—1755 CFM <p>Note To maintain proper air circulation through the Catalyst switch chassis, we recommend that you maintain a minimum 6-inch (15 cm) separation between a wall and the chassis air intake or a wall and the chassis air exhaust. You should also allow a minimum separation of 12 inches (30.5 cm) between the hot air exhaust on one chassis and the air intake on another chassis. Failure to maintain adequate air space can cause the chassis to overheat and the system to fail. On Catalyst chassis in which the airflow is from front to back, the chassis may be placed side-by-side.</p>

1. RU = rack units

